

PipeDrive

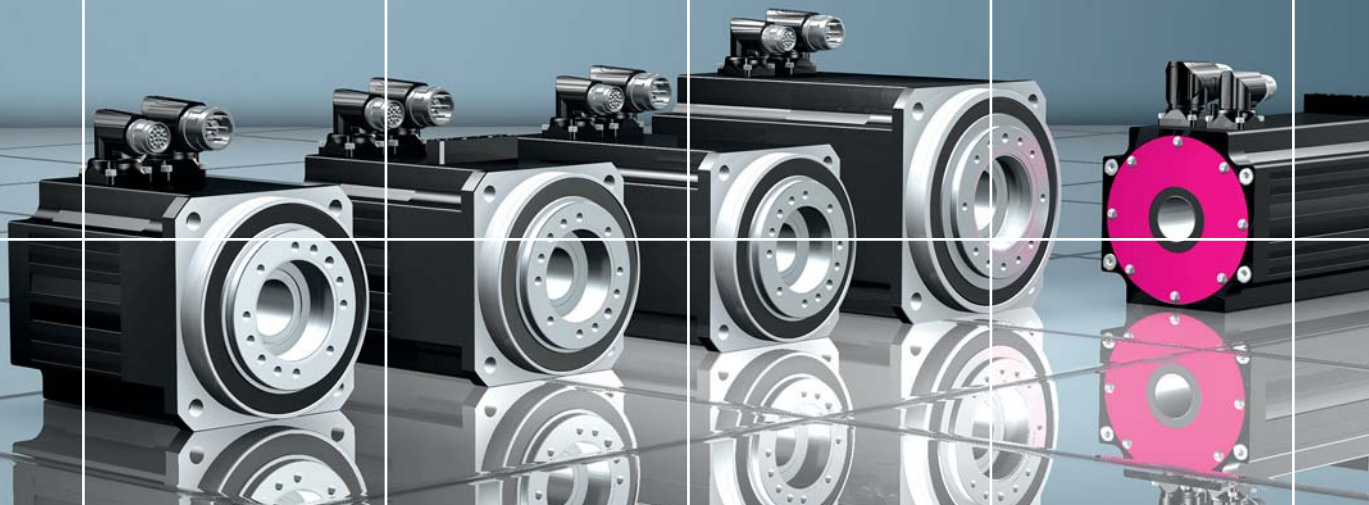

Super compact
servo geared motors
with flange mount hollow
bore for feeding through
media and energy

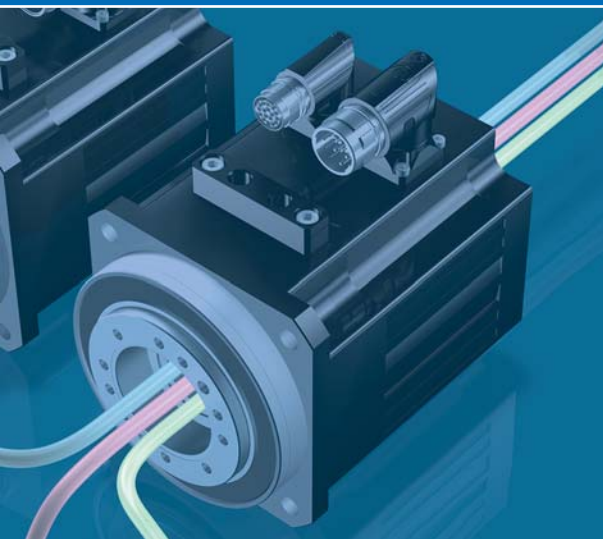

STÖBER

PipeDrive. Maximum power density

Servo drive with hollow bore

The central, generously designed flange mount hollow bore for this high-class servo drive makes it possible to provide supplies (power cables, pipes, hoses), shafts and laser light etc. through the motor. To protect these components and media, the flange mount hollow bore is clad with a continuous pipe.

The direct, central path through the complete drive simplifies typical designs for industrial robots, machinery, machine tools, automatic assembly machines, handling equipment and laser machine tools.

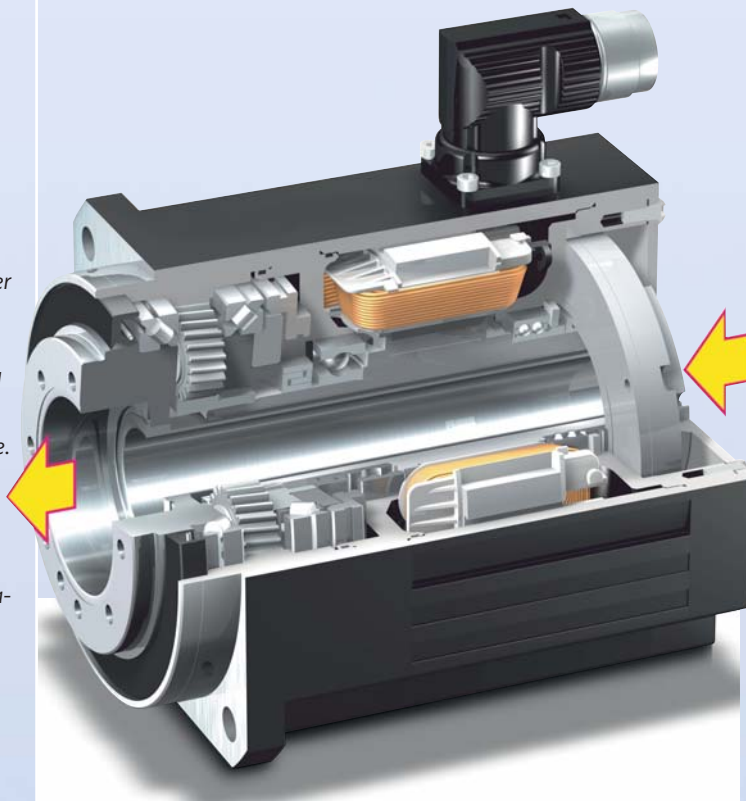

New, super compact hollow bore servo motor

A crucial element of the extremely short length of this new drive is the highly modern motor design.

A basic prerequisite for the super-short design of the new series is the industrial implementation of a tooth winding using orthocyclic linear winding technology. This feature makes it possible to manufacture the stator windings with the highest possible copper fill factor. The winding technology increases the motor power output by approx. 80%. For this reason it is possible to shorten the length of the motor by almost half without reducing the power output.

Due to the new structural design of all components and a series of further computer-based fine tuning methods, it was possible to achieve balanced motor behavior with powerful torque, high dynamic performance and precise constant speed running.

If necessary, the dynamic behavior can be modified

Powerful torque, high stiffness, low total weight

Motor and gearbox are optimized for maximum torque. For higher torques the liquid cooling or external fan options can be used.

With an extremely compact structure, this servo drive has a very high torsional stiffness.

Due to the weight-saving design, the PipeDrive is particularly suitable for applications in which the motor is also moved.

New planetary gear unit with flange mount hollow bore

To match the short length of the hollow bore motor, an equally short hollow bore planetary gear unit with high quality bearing technology was developed.

This gear unit can be of a one, two or three-stage design. In all versions it provides a stable output bearing with very high tilting stiffness and a high permissible tilting moment.

PipeDrive servo geared motor
Type PYEZ
With flange mount hollow bore and
EnDat® inductive absolute encoder
as a digital feedback system

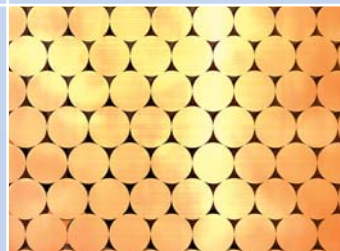

Enlarged image of an orthocyclically wound motor coil

This complex precision winding technology is used by STÖBER for the series production of the EZ/EZF motors



Also available as EZF flange mount hollow bore motor, without directly attached gear unit

Integrated system technology – from the start

Designed and developed from the know-how of the experienced system manufacturer

The design and manufacture of this innovative geared motor is based on decades of application experience, paired with mechatronic production know-how and the willingness to tread new ground in drive technology.

The initial range:

The new PipeDrive geared motors will initially be available in the sizes 5 and 7.

The hollow bore gear unit can be 1, 2 or 3-stage with the ratios 3, 9 and 27.

The hollow bore motors are available in the lengths 1, 2, 3 and 5. This figure relates to the number of rotor segments in each case. The sizes are in 25 mm steps.



An EnDat® absolute encoder is used for the feedback system



PipeDrive servo geared motor, type PY 501 EZ 501, one-stage gear unit with flange mount hollow bore, convection cooled

PipeDrive servo geared motor type PY 702 EZ 701, two-stage gear unit with flange mount hollow bore and adapter for liquid cooling

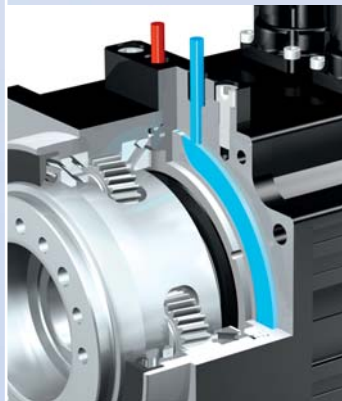

As an option the flange between the motor and gear unit can be designed as a liquid cooling feature. The section shows the cooling channel
The heat dissipated can be utilized to increase energy efficiency



The torque and output speed of the geared motor can be optimized by selecting from four motor lengths and three gearbox stages

The highest possible power density is achieved with the compact design

In the figure on the left: Geared motor with one gear unit stage and motor type EZ 705 (relatively high torque with low ratio)

In the figure on the right: Geared motor with three gear unit stages and motor type EZ 701

Servo geared motor PYEZ

Motor type		EZH 501			EZH 502			EZH 503			EZH 505		EZH 701			EZH 702			EZH 703			EZH 705	
Ratio i (1 to 3-stage)	[-]	3	9	27	3	9	27	3	9	27	3	9	3	9	27	3	9	27	3	9	27	3	9
Backlash	[arcmin]	3	4	4	3	4	4	3	4	4	3	4	3	4	4	3	4	4	3	4	4	3	4
Speed max.	[1/min]	1500	500	150	1500	500	150	1500	500	150	1500	500	1200	400	130	1200	400	130	1200	400	130	1200	400
Acceleration torque	[Nm]	30	90	200	50	150	200	70	200	200	90	200	50	150	450	80	240	500	110	330	500	180	500
Inside-Ø hollow bore	[mm]	28										38											
Weight	[kg]	7.8	9.4	11.0	9.0	10.6	12.3	11.1	12.7	14.4	14.4	16.1	13.6	16.5	19.5	16.2	19.2	22.1	18.8	21.8	24.7	24.2	27.1

The complete PipeDrive servo axis

With this extremely compact, complete STÖBER system solution, the entire potential of the optimally matched components can be utilized.

① POSITool software suite

Universal user software for all functions from engineering to commissioning. Firmware and application tools are included

② POSIDYN® SDS 5000 servo inverter

Has a secure remote maintenance function and a self-configuring Integrated Bus (IGB) for the communication between max. 32 servo inverters.

③ PipeDrive servo geared motor

High torque servo geared motor with flange mount hollow bore.



Service

The STÖBER service system comprises 36 expert partners in Germany and more than 80 companies in the STÖBER SERVICE NETWORK world-wide.

This full service concept guarantees local expertise and availability when needed.

The concept is supplemented by the remote maintenance concept for the servo inverters in the POSIDYN® SDS 5000 series.

In general, the service specialists in the Pforzheim factory can be reached at any time via a 24/7 service hotline.

When necessary, urgent action to correct a problem can be put in train immediately.

24/7 service hotline
+49(0)180 5 786323

STÖBER ANTRIEBSTECHNIK GmbH + Co. KG

Kieselbronner Str. 12
75177 PFORZHEIM
GERMANY
Phone +49 (0)7231 582-0
Fax +49 (0)7231 582-1000
Email: mail@stoerber.de
www.stoerber.de

STOBER DRIVES LTD.

ESSEX EN9 1JH
GREAT BRITAIN
Email: mail@stoerber.co.uk
www.stoerber.co.uk

STOBER DRIVES, INC.

MAYSVILLE, KY 41056
USA
Email: sales@stoerber.com
www.stoerber.com

STÖBER ANTRIEBSTECHNIK GmbH

4662 STEYRERMÜHL
AUSTRIA
Email: office@stoerber.at
www.stoerber.at

STOBER CHINA

BEIJING 100004
CHINA
Email: qinghua.bao@stoerber.cn
www.stoerber.cn

STOBER S.a.r.l.

69300 CALUIRE ET CUIRE
FRANCE
Email: mail@stoerber.fr
www.stoerber.fr

STÖBER TRASMISSIONI s.r.l.

20017 MAZZO DI RHO (MILANO)
ITALY
Email: info@stoerber.it
www.stoerber.it

STÖBER Schweiz AG

5453 REMETSCHWIL
SWITZERLAND
Email: info@stoerber.ch
www.stoerber.ch



STÖBER