



# PRECISION MOTION AND DISPLACEMENT TRANSDUCERS



Distributed by  
Machine Automation  
Products LLC  
1074 Yellow Pine Street  
Coon Rapids, MN 55433

Phone 763 757 0198  
Fax 763 757 4724





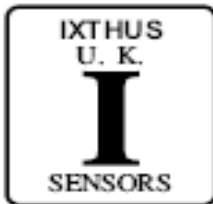







**CONDUCTIVE PLASTIC TECHNOLOGY**  
**LONDON, U.K.**



# Precision Conductive Plastic Linear Motion Transducer

## Content

 □ 33 Section	<b>KTC</b> Standard Linear Transducer 50 - 1250mm Pulling Rod Type	. . . . . 3 - 6
 □ 38 Section	<b>KTF</b> Standard Linear Transducer 50 - 3000mm Rodless Type	. . . . . 7 - 10
 ∅ 35 Section	<b>PCM</b> Jumbo Linear Transducer 50-900mm Pulling Rod Type	. . . . . 11 - 12
 □ 18 Section	<b>PA1</b> Mini Linear Transducer 10-450mm Pulling Rod Type	. . . . . 13 - 14
 □ 18 Section	<b>PY1</b> Mini Linear Transducer 10-450mm Pull & Push Rod Type	. . . . . 15 - 16
 □ 18 Section	<b>PY2</b> Mini Linear Transducer 10-50mm Spring Loaded Ball Head Type	. . . . . 17 - 18
 □ 18 Section	<b>PY3</b> Mini Linear Transducer 10-50mm Spring Loaded Roller Head Type	. . . . . 19 - 20
 ∅ 12.9 Section	<b>PZ12</b> Mini Linear Transducer 10-150mm Pulling Rod Type	. . . . . 21 - 22
 ∅ 19 Section	<b>PZ34</b> Mini Linear Transducer 10-250mm Pulling Rod Type	. . . . . 23 - 24
	<b>IC</b> Conductive Plastic Element For Mounting Inside Hydraulic or Pneumatic Cylinder	. . . . . 25 - 26
<b>Appendix</b>	Motion and Displacement Transducer Conductive Plastic	. . . . . 27 - 30

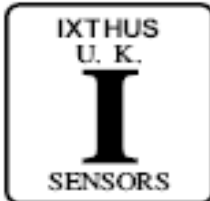

# KTC

## LINEAR MOTION POSITION SENSORS

□ 33 Section, STANDARD 50-1250mm

### Pulling Rod Type



#### Unique Features

- Durable bearing and slider
- Anodized Aluminium Housing
- Smooth Low Noise Output from Conductive Plastic Track
- Very Long Life
  - >100 x 10<sup>6</sup> Cycles
  - >25 x 10<sup>6</sup> m
- Stroke : 50-1250mm
- Outstanding Linearity : ± 0.05%
- High Resolution : Infinite
- Excellent Repeatability : ± 0.01mm
- Max operating speed : 10m/s max.
- DIN 43650 ISO 4400 Connector
- Fuse Protected optional
- Operating temperature : -30 ~100°C
- Storage Temperature : -50 ~120°C

KTC standard linear transducers are designed for direct absolute measurement and are available in different stroke lengths up to 1250mm.

The sensors give exceptional resolution with repeatability of ±0.01mm and outstanding linearity of ±0.05% maximum.

The sensors can be directly mounted into the mechanical system eliminating the use of racks and pinions or similar devices.

The KTC series has a solid stainless steel shaft with long bearings in the housing for a robust and smooth operation with long life. The slider has a ball coupling which reduces the effects of misalignment with the actuating part.

An improved technique for making connection to resistance track (Double Trimming Technique) ensures the higher degrees of reliability and linearity, while multi-fingers wipers stabilize output signals, even in the most adverse working conditions.

The fixing feet are adjustable to the desired positions.

Technical Specifications	
Sealing - KTC	IP60
Sealing - KTC-P	IP65
Current	≤ 10mA
Resistance	≤ 1mA
Wiper	≤ 2N (KTC)
Operating Force	≤ 10N (KTC-P)
Power Consumption	3W-10W
Output Smoothness	<± 0.1% against input voltage
Input Voltage	60 V Max
Insulation Voltage	500V-1 min Residue < 5 μA
Vibration	IEC 68-2-6:1982 10g
Shock	IEC 68-2-29:1968 40g



# KTC

## LINEAR MOTION POSITION SENSORS

□ 33 Section, STANDARD 50-1250mm

**ORDER CODE**

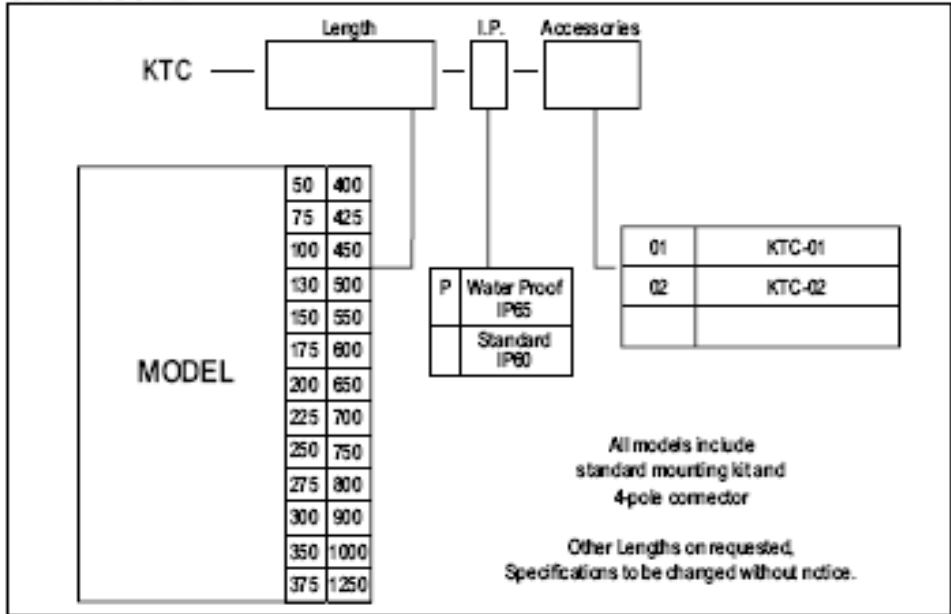

KTC series		50	75	100	130	150	175	200	225	250	275	300	350	375	400	425	450	500	550	600	650	700	750	800	900	1000	1250		
Total Electrical Travel (T.E)	mm	53	78	103	133	153	178	204	229	254	279	304	354	380	406	432	457	508	558	609	659	710	762	812	914	1017	1271		
Active Electrical Travel (A.E)	mm	51	76	101	131	151	176	202	227	252	277	302	352	378	404	430	455	506	556	607	657	708	760	810	912	1015	1269		
Resistance ±20%	kΩ	5	5	5	5	5	5	5	5	5	5	5	5	5	5	5	5	5	5	5	10	10	10	10	10	10	20		
Independent Linearity	±%	0.05	0.05	0.05	0.05	0.05	0.05	0.05	0.05	0.05	0.05	0.05	0.05	0.05	0.05	0.05	0.05	0.05	0.05	0.05	0.05	0.05	0.05	0.05	0.05	0.05	0.05		
Mechanical Travel (M.T)	mm	59	84	109	139	159	184	210	235	260	285	310	360	386	412	437	463	518	568	619	669	720	772	822	924	1027	1281		
Resolution		infinite																											
Recommended Cursor Current	µA	< 1																											
Temperature Range	°C	-30 to +100																											
Dimensions (A)	mm	114	139	164	195	215	241	266	291	316	341	367	417	444	469	494	520	570	623	672	726	776	825	879	977	1086	1341		

\*Dimensions for reference only



# KTC

## LINEAR MOTION POSITION SENSORS

□ 33 Section, STANDARD 50-1250mm

### MECHANICAL DIMENSIONS KTC

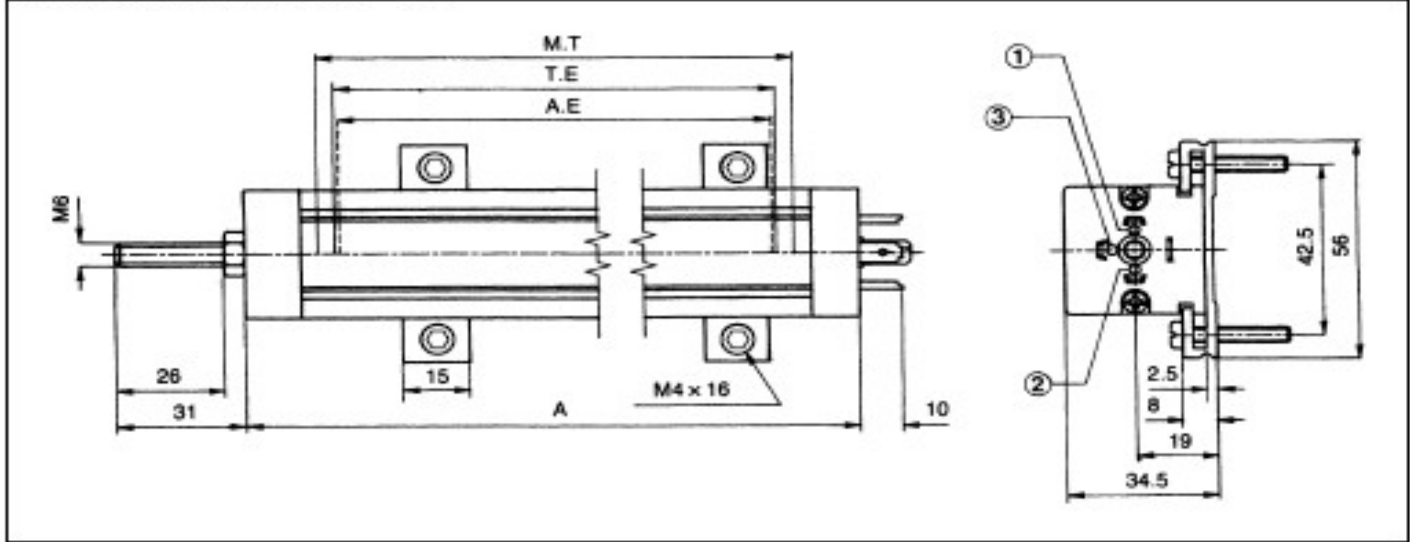

### ROD END BEARING (KTC-01)

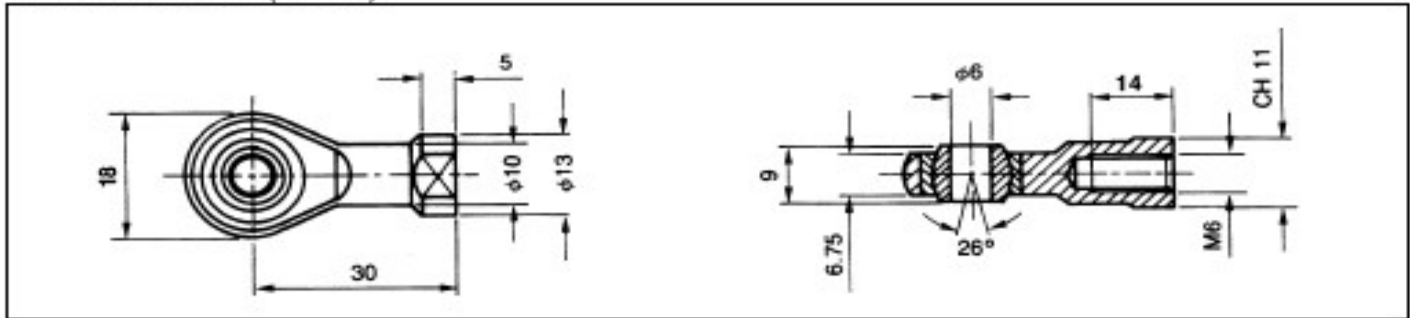

### LINK BALL (KTC-02)

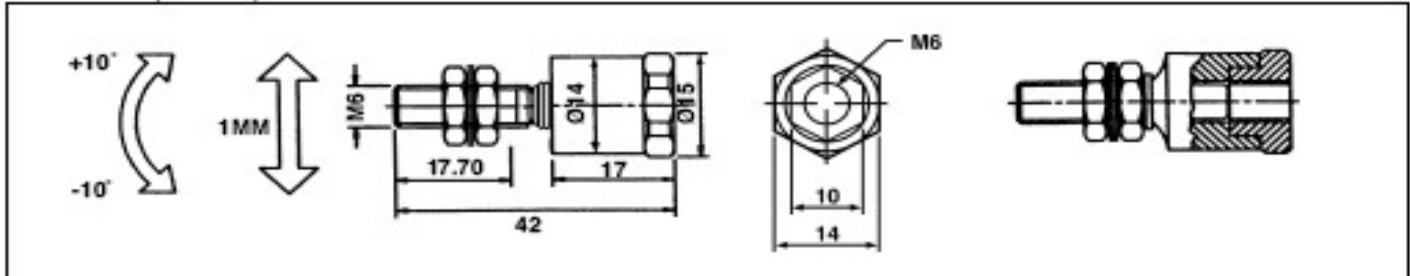



# KTC

## LINEAR MOTION POSITION SENSORS

□ 33 Section, STANDARD 50-1250mm

### RECOMMENDED MEASUREMENT CIRCUIT

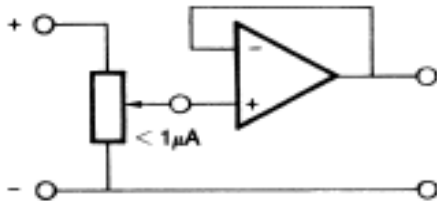

**Important:**  
 The published technical data are applicable only when the transducer is used correctly, and in accordance with the user manual / instructions. The KTC linear Position transducers must be used as voltage dividers with a maximum current in the wiper contact of 1  $\mu$ A; should the system downstream require more current, further circuitry will be required.

### ELECTRICAL CONNECTIONS

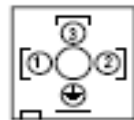
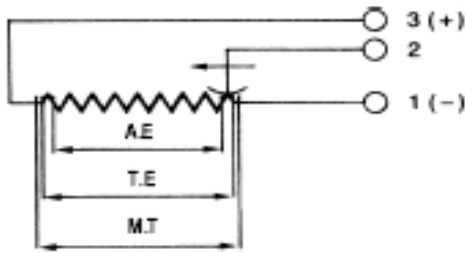

Connector Plug  
Pin Assignment

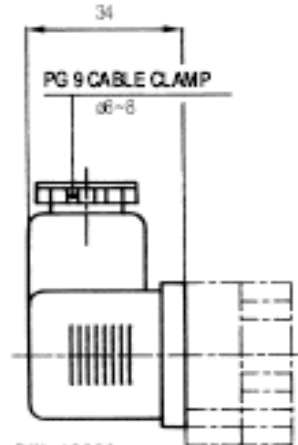

DIN 43650  
IP65-ISO4400



# KTF

## LINEAR MOTION POSITION SENSORS

□ 38 Section, STANDARD 50-3000mm

### Rodless Type



#### Unique Features

- Durable bearing and slider
- Anodized Aluminium Housing
- Smooth Low Noise Output from Conductive Plastic Tack
- Very Long Life
  - >100 x 10<sup>6</sup> Cycles
  - >25 x 10<sup>6</sup> m
- Stroke : 50-3000mm
- Outstanding Linearity
  - : ±0.07%(50-375mm)
  - : ±0.05%(400-3000mm)
- High Resolution : Infinite
- Excellent Repeatability : ± 0.01mm
- Max operating speed : 10m/s max.
- DIN 43650 ISO 4400 Connector
- Fuse Protected optional
- Operating temperature : -30~100°C
- Storage Temperature : -50~120°C

KTF standard linear transducers are designed for direct absolute measurement and are available in stroke lengths up to 3000mm.

The rodless design allows the actuator to be driven from side and along the whole length.

A magnetically restrained stainless steel band covering all the opening through which the actuator operates.

The KTF series is a rodless version which provides minimum installation length. The slider has a ball coupling which reduces the effects of mis-alignment with the actuating part and eliminates forces generating from angular off-sets transmitting to the bearing surfaces.

An improved technique for making connection to resistance track (Double Trimming Technique) ensures the higher degrees of reliability and linearity, while multi-fingers wipers stabilize output signals, even in the most adverse working conditions.

The fixing feet are adjustable to the desired positions.

Technical Specifications		
Sealing - KTF		IP50
Current	Resistance	≤ 10mA
	Wiper	≤ 1mA
Operating Force		≤ 2N
Power Consumption		3W-10W
Output Smoothness		<± 0.1% against input voltage
Input Voltage		60 V Max
Insulation Voltage		500V-1 min Residue < 5 μ A
Vibration		IEC 68-2-6:1982 10g
Shock		IEC 68-2-29: 1968 40g



# KTF

## LINEAR MOTION POSITION SENSORS

□ 38 Section, STANDARD 50-3000mm

### ORDER CODE

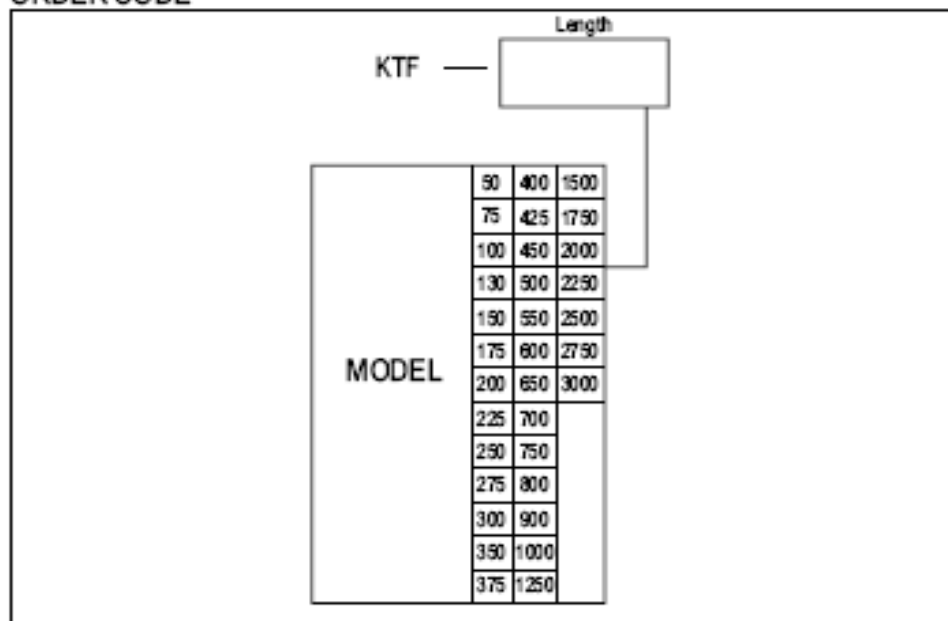

KTF series		50	75	100	130	150	175	200	225	250	275	300	350	375	400	425	450	500	550	600	650	700	750	800	900	1000	1250	1500	1750	2000	2250	2500	2750	3000	
Total Electrical Travel (TE)	mm	80	76	100	130	150	176	204	229	254	279	304	358	380	406	432	457	508	558	608	659	710	762	812	914	1017	1211	1521	1771	2021	2270	2526	2776	3030	
Active Electrical Travel (AE)	mm	81	76	101	131	151	176	202	227	252	277	302	352	378	404	430	455	506	556	607	657	708	760	810	912	1015	1209	1519	1769	2019	2271	2524	2776	3028	
Resistance ±20%	kΩ	5	5	5	5	5	5	5	5	5	5	5	5	5	5	5	5	5	5	5	5	5	5	5	5	5	5	5	5	5	5	5	5	5	5
Independent Linearity	%	0.07	0.07	0.07	0.07	0.07	0.07	0.07	0.07	0.07	0.07	0.07	0.07	0.07	0.05	0.05	0.05	0.05	0.05	0.05	0.05	0.05	0.05	0.05	0.05	0.05	0.05	0.05	0.05	0.05	0.05	0.05	0.05	0.05	0.05
Mechanical Travel (MT)	mm	80	88	113	143	163	188	214	239	264	289	314	368	390	416	442	467	518	568	619	669	720	772	822	924	1027	1231	1531	1781	2031	2280	2536	2788	3040	
Resolution		infinite																																	
Recommended Cursor Current	µA	<1																																	
Temperature Range	°C	-30 to +100																																	
Dimensions (A)	mm	198	223	248	278	298	323	349	374	399	424	449	499	525	551	577	602	653	703	754	804	855	907	957	1059	1162	1416	1666	1916	2166	2416	2671	2923	3175	

\* Dimensions for reference only



# KTF

## LINEAR MOTION POSITION SENSORS

□ 38 Section, STANDARD 50-3000mm

### MECHANICAL DIMENSIONS KTF

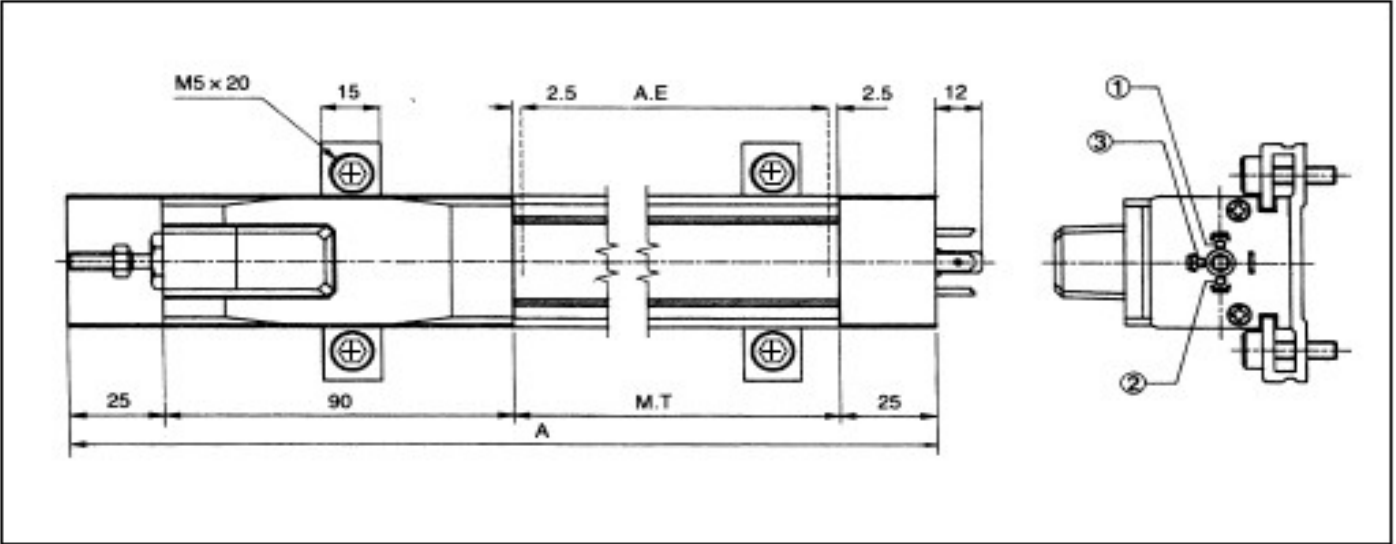

### COUPLING JOINT

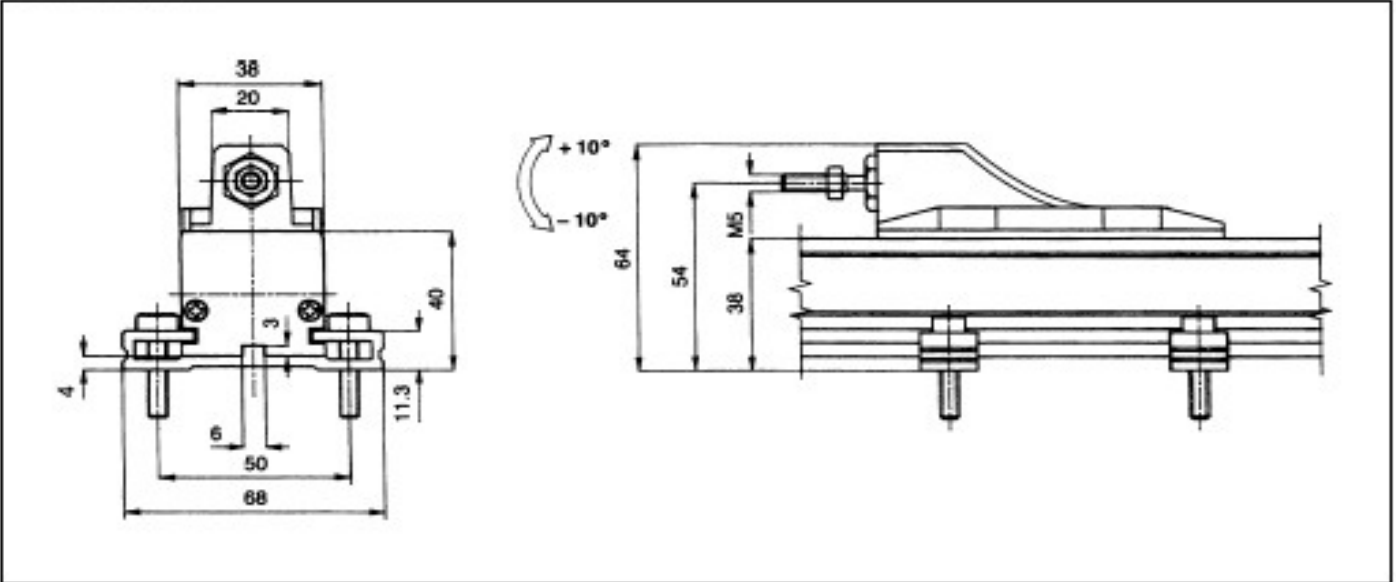



# KTF

## LINEAR MOTION POSITION SENSORS

□ 38 Section, STANDARD 50-3000mm

### RECOMMENDED MEASUREMENT CIRCUIT

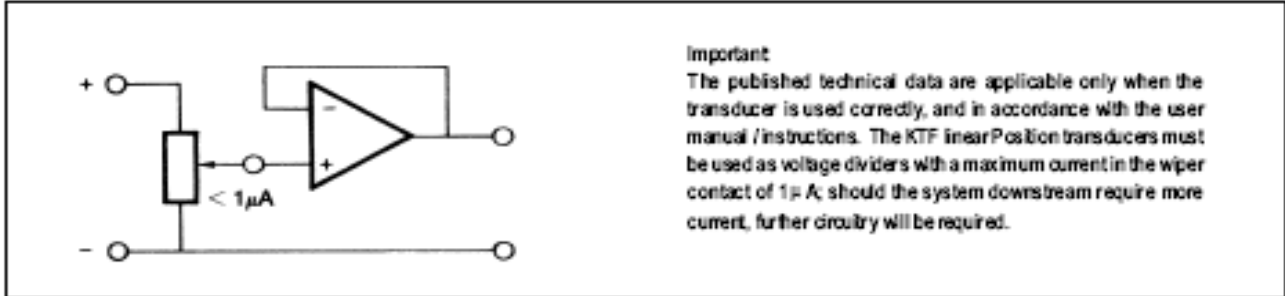

### ELECTRICAL CONNECTIONS

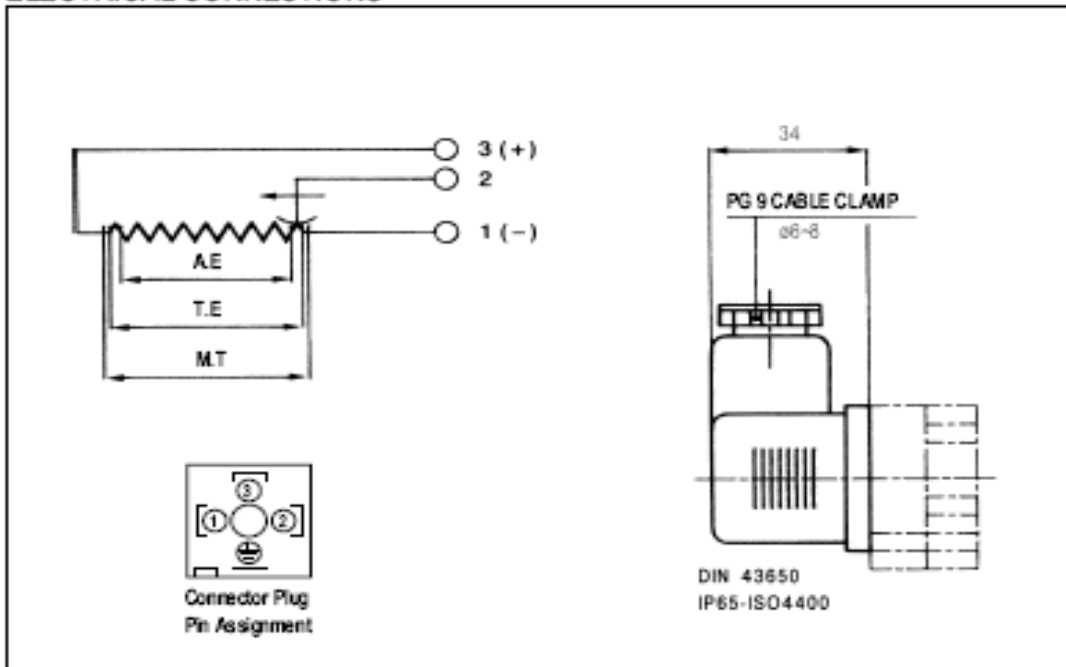



# PCM

## LINEAR MOTION POSITION SENSORS

Ø 35 Section, STANDARD 50-900mm

### Pulling Rod Type



The sensor is built for easy mounting by double built in connectors, enable a large angle of misalignment and without back-lashes. A built-in connector system that is designed of reliability and safety contributes to excellent performance. These series can be used in a wide range of applications in mechanical and vehicle engineering industries as well as in automation and robotics technologies, combining remarkable robustness with high accuracy.

#### Unique Features

- Anodized aluminium housing
- Stroke lengths from 50 to 900mm
- Twin-bearing actuating rod
- Excellent linearity to  $\pm 0.05\%$
- Repeatability better than 0.01mm
- Smooth Low Noise Output from Conductive Plastic Tack
- Very Long Life
  - >100 x 10<sup>6</sup> Cycles
  - >25 x 10<sup>6</sup> m
- Stroke : 50-900mm
- Outstanding Linearity :  $\pm 0.05\%$
- High Resolution : Infinite
- Excellent Repeatability :  $\pm 0.01\text{mm}$
- Max operating speed : 5m/s max.
- C193 4-PIN Connector
- Fuse Protected optional
- Operating temperature : -30 ~100°C
- Storage Temperature : -50 ~120°C

#### Technical Specifications

Sealing - PCM	IP65
Current Resistance	$\leq 10\text{mA}$
Wiper	$\leq 1\text{mA}$
Operating Force	$\leq 10\text{N}$
Power Consumption	3W-10W
Output Smoothness	$< \pm 0.1\%$ against input voltage
Input Voltage	60 V Max
Insulation Voltage	500V-1 min Residue $< 5 \mu\text{A}$
Vibration	IEC 68-2-6:1982 10g
Shock	IEC 68-2-29:1968 40g

#### ORDER CODE

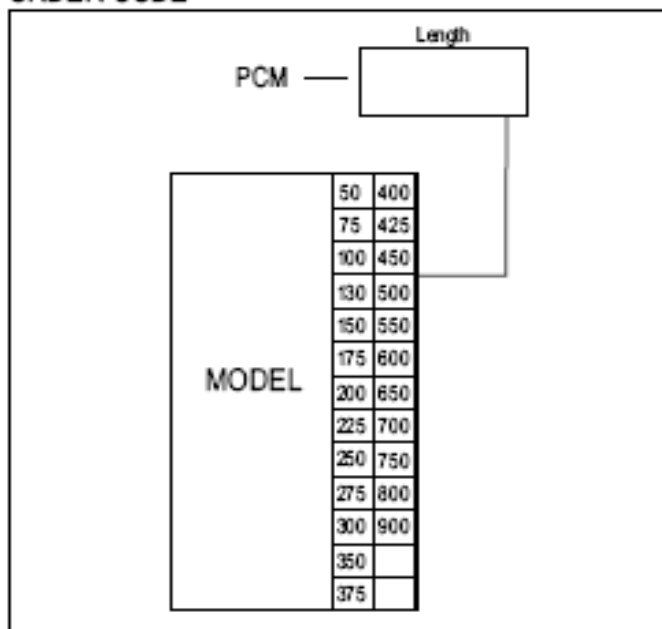





# PA1

## LINEAR MOTION POSITION SENSORS

Mini Series □ 18 Section, STANDARD 10-450mm

### Pulling Rod Type

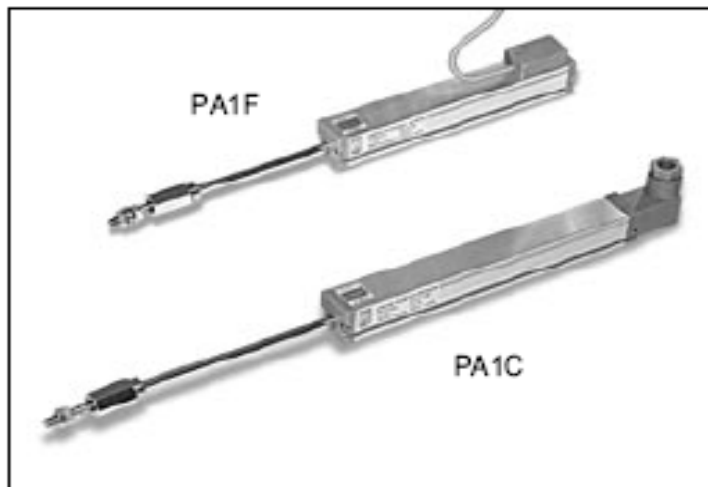

This mini position transducer is designed for direct absolute measurement and available in stroke length up to 450mm. The mini design is suitable for mounting in instruments or machines with limited space.

An improved technique for making connection to resistance track (Double Trimming Technique) ensures the higher degrees of reliability and linearity, while multi-fingers wipers stabilize output signals, even in the most adverse working conditions.

The fixing feet are adjustable to the desired positions.

#### Unique Features

- Mini design for limited space
- Anodised Aluminium Housing
- Double slide and bearing
- Standard Coupling joints
- Very Long Life >100 x 10<sup>6</sup> Cycles
- Stroke length >25 x 10<sup>6</sup> m
- Outstanding Linearity up to : 10-450mm
- High Resolution : ±0.05%
- Excellent Repeatability : Infinite
- Max operating speed : ± 0.01mm
- PA1C - 4-pin C193 connector : 5m/s max.
- PA1FS - standard 1m cable
- Sealing IP 40 standard (IP 65 optional)
- Fuse Protected optional
- Operating temperature : -30 ~100°C
- Storage Temperature : -50 ~120°C

Technical Specifications	
Sealing - PA1C/PA1F	IP40
Sealing - optional	IP65
Current Resistance	≤ 10mA
Wiper	≤ 1mA
Operating Force	≤ 1.2N (IP40)
	≤ 5N (IP65)
Power Consumption	3W-10W
Output Smoothness	<± 0.1% against input voltage
Input Voltage	60 V Max
Insulation Voltage	500V-1 min Residue < 5 μA
Vibration	IEC 68-2-6:1982 10g
Shock	IEC 68-2-29:1968 40g

#### ORDER CODE

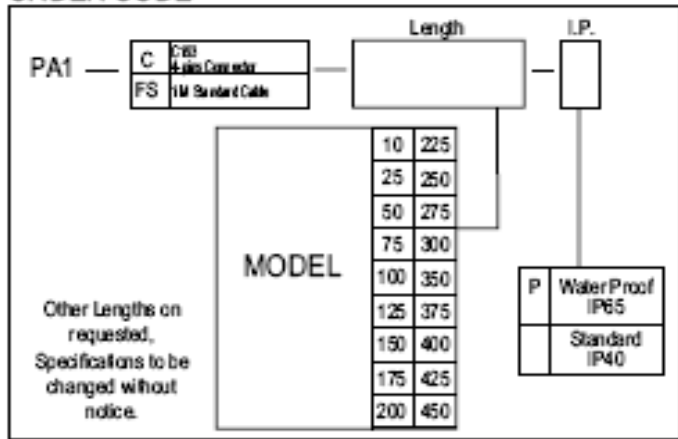



# PA1

## LINEAR MOTION POSITION SENSORS

Mini Series □ 18 Section, STANDARD 10-450mm

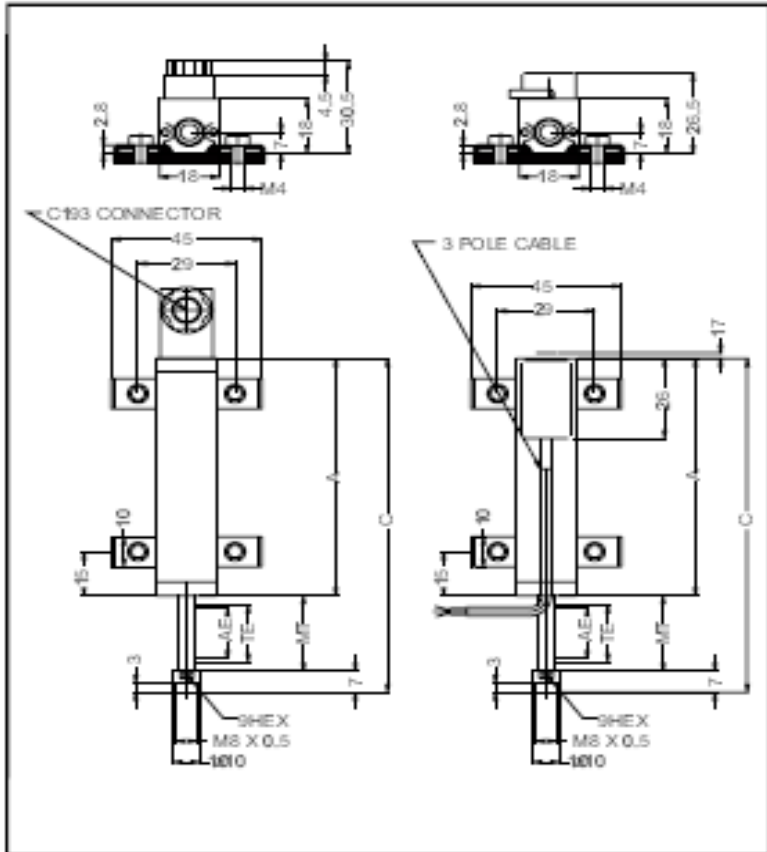

### ELECTRICAL CONNECTIONS

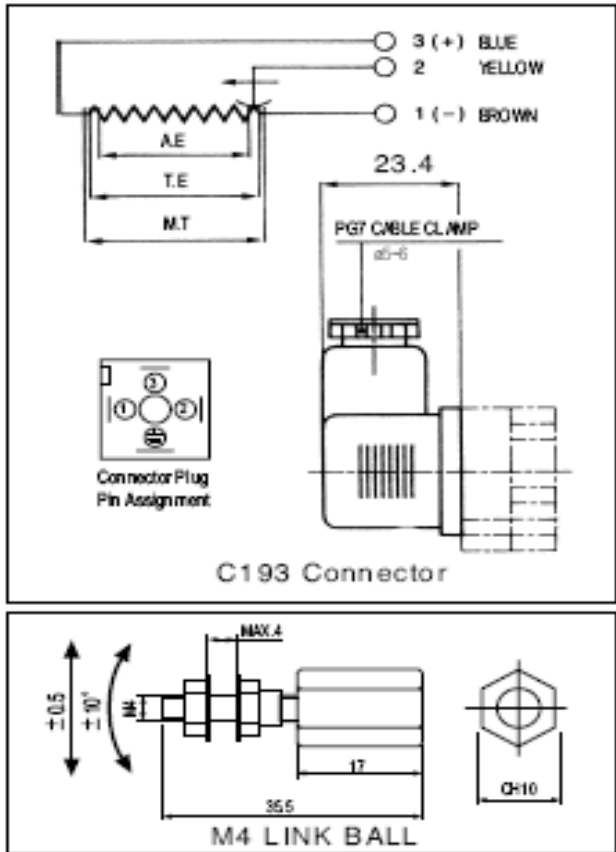

PA1 series		10	25	50	75	100	125	150	175	200	225	250	275	300	350	375	400	425	450	
Total Electrical Travel (T.E)	mm	11	26	51	76	101	126	151	177	202	227	252	277	302	353	378	403	428	453	
Active Electrical Travel (A.E)	mm	10	25	50	75	100	125	150	176	201	226	251	276	301	352	377	402	427	452	
Resistance ±20%	kΩ	1	1	5	5	5	5	5	5	5	5	5	5	5	5	5	5	5	5	
Independent Linearity	±%	0.3	0.2	0.1	0.1	0.1	0.05	0.05	0.05	0.05	0.05	0.05	0.05	0.05	0.05	0.05	0.05	0.05	0.05	
Mechanical Travel (M.T)	mm	15	30	55	80	105	130	155	180	205	230	255	280	305	355	380	405	430	455	
Resolution		infinite																		
Recommended Cursor Current	µA	<1																		
Temperature Range	°C	-30 to +100																		
Dimensions (A)	mm	58.5	74.5	99.5	124.5	149.5	174.5	199.5	224.5	249.5	274.5	299.5	324.5	349.5	399.5	424.5	449.5	474.5	499.5	
Dimensions (C)	mm	83.2	113.2	163.2	213.2	263.2	313.2	363.2	413.2	463.2	513.2	563.2	613.2	663.2	763.2	813.2	863.2	913.2	963.2	

\* See notes for reference only



# PY1

## LINEAR MOTION POSITION SENSORS

Mini Series □ 18 Section, STANDARD 10-450mm

### Pull & Push Rod Type

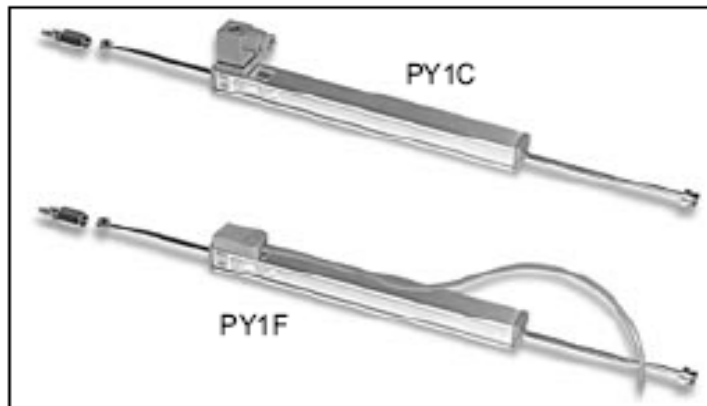

This mini position transducer is designed for direct absolute measurement and available in stroke length up to 450mm. The mini design is suitable for mounting in instruments or machines with limited space.

An improved technique for making connection to resistance track (Double Trimming Technique) ensures the higher degrees of reliability and linearity, while multi-fingers wipers stabilize output signals, even in the most adverse working conditions.

The fixing feet are adjustable to the desired position.

The pull & push rod mounting in 2 ways directions enables more stable movement, and extra low operating forces.

### Unique Features

- Mini design for limited space
- Anodised Aluminium Housing
- Double slide and bearing
- Standard Coupling Joints
- Very Long Life >100 x 10<sup>6</sup> Cycles  
>25 x 10<sup>6</sup> m
- Stroke : 10-450mm
- Outstanding Linearity up to : ± 0.05%
- High Resolution : Infinite
- Excellent Repeatability : ± 0.01mm
- Max operating speed : 5m/s max.
- PY1C - 4-pin C193 connector
- PY1FS - standard 1m cable
- Sealing IP 40 standard (IP 65 optional)
- Fuse Protected optional
- "Pull" and "Push" Rod type
- Operating temperature : -30 ~100°C
- Storage Temperature : -50 ~120°C

Technical Specifications	
Sealing - PY1C/PY1F	IP40
Sealing - optional	IP65
Current	≤ 10mA
Resistance	≤ 1mA
Wiper	≤ 1.2N (IP40) ≤ 5N (IP65)
Operating Force	3W-10W
Power Consumption	<± 0.1% against input voltage
Output Smoothness	60 V Max
Input Voltage	500V-1 min Residue < 5 μA
Insulation Voltage	IEC 68-2-6:1982 10g
Vibration	IEC 68-2-29:1968 40g
Shock	

### ORDER CODE

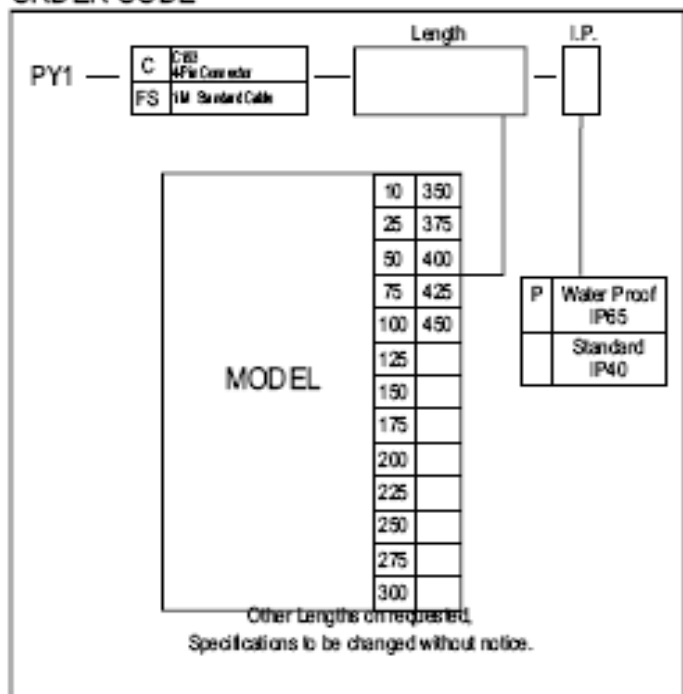



# PY1

## LINEAR MOTION POSITION SENSORS

Mini Series □ 18 Section, STANDARD 10-450mm

### ELECTRICAL CONNECTIONS

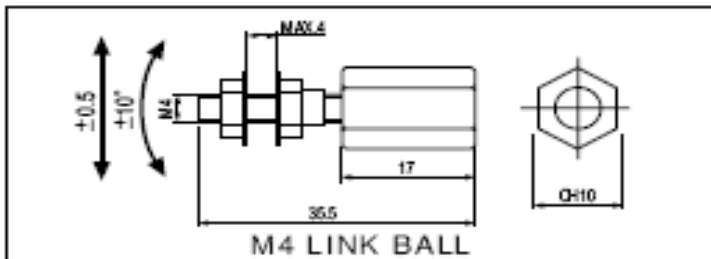
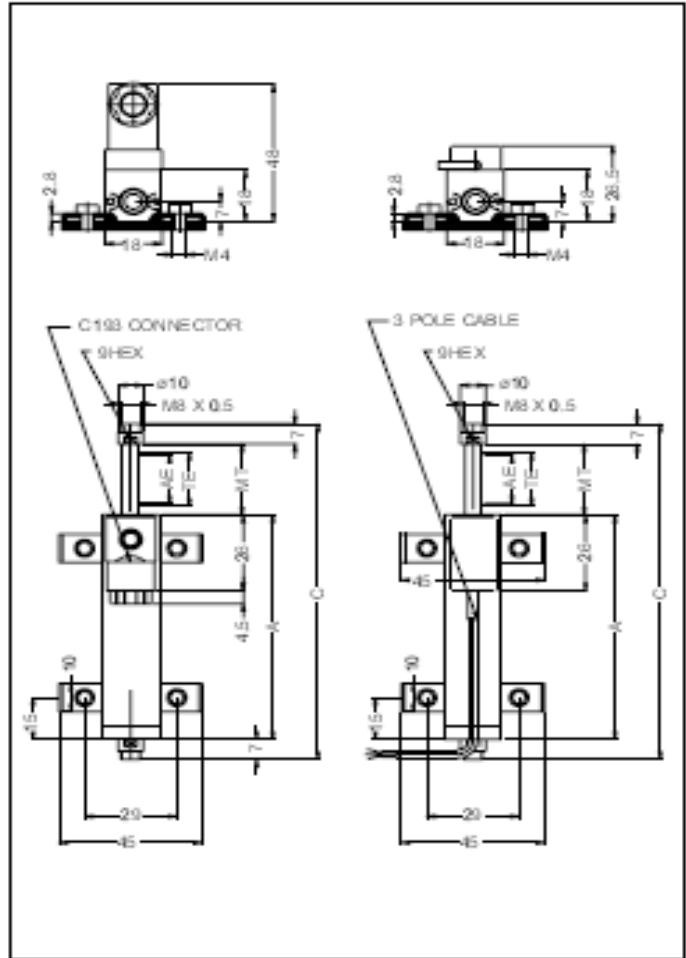
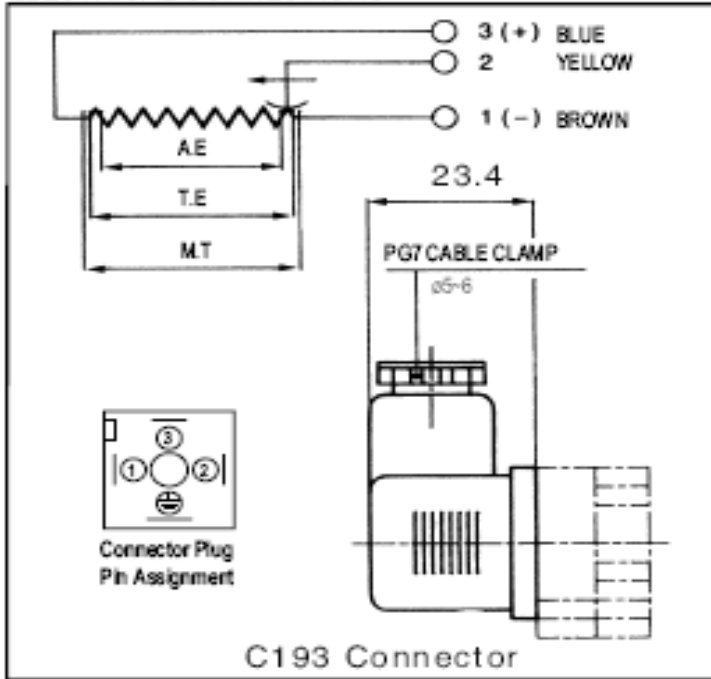

PY1 series		10	25	50	75	100	125	150	175	200	225	250	275	300	350	375	400	425	450	
Total Electrical Travel (T.E)	mm	11	26	51	76	101	126	151	177	202	227	252	277	302	353	378	403	428	453	
Active Electrical Travel (A.E)	mm	10	25	50	75	100	125	150	175	201	226	251	276	301	352	377	402	427	452	
Resistance ±20%	kΩ	1	1	5	5	5	5	5	5	5	5	5	5	5	5	5	5	5	5	
Independent Linearity	±%	0.3	0.2	0.1	0.1	0.1	0.05	0.05	0.05	0.05	0.05	0.05	0.05	0.05	0.05	0.05	0.05	0.05	0.05	
Mechanical Travel (M.T)	mm	15	30	55	80	105	130	155	180	205	230	255	280	305	355	380	405	430	455	
Resolution		infinite																		
Recommended Cursor Current	µA	<1																		
Temperature Range	°C	-30 to +100																		
Dimensions (A)	mm	48	63	88	113	138	163	188	213	238	263	288	313	338	366	413	438	463	488	
Dimensions (C)	mm	77	107	157	207	257	307	357	407	457	507	557	607	657	757	807	857	907	957	

\* Dimensions for reference only



# PY2

## LINEAR MOTION POSITION SENSORS

Mini Series □ 18 Section, STANDARD 10-50mm

### Ball Head Pre-loaded Spring Type

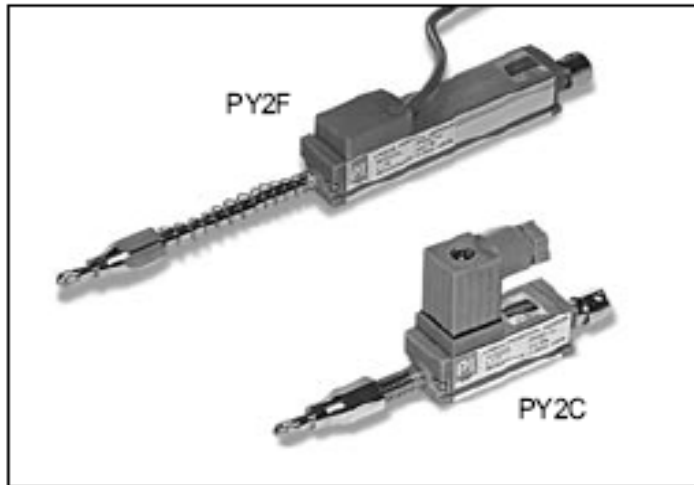

This mini position transducer is designed for direct absolute measurement and available in stroke length up to 50mm. The mini design is suitable for mounting in instruments or machines with limited space and specially design for cam-following application.

An improved technique for making connection to resistance track (Double Trimming Technique) ensures the higher degrees of reliability and linearity, while multi-fingers wipers stabilize output signals, even in the most adverse working conditions.

The fixing feet are adjustable to the desired positions.

#### Unique Features

- Harden steel ball head for measurement of cam-following application
- Mini design for limited space
- Anodised Aluminium Housing
- Double slide and bearing
- Very Long Life
  - >100 x 10<sup>6</sup> Cycles
  - >25 x 10<sup>6</sup> m
- Stroke : 10-50mm
- Outstanding Linearity up to : ± 0.1%
- High Resolution : Infinite
- Excellent Repeatability : ± 0.01mm
- Max operating speed : 5m/s max.
- PY2C - 4-pin C193 connector
- PY2FS - standard 1m cable
- Sealing IP 40 standard (IP 65 optional)
- Fuse Protected optional
- Anti - rotating shaft device optional

Technical Specifications	
Sealing - PY2C/PY2FS	IP40
Sealing - optional	IP65
Current Resistance	≅ 10mA
Wiper	≅ 1mA
Operating Force	≅ 1.2N (IP40)
	≅ 5N (IP65)
Power Consumption	3W-10W
Output Smoothness	<± 0.1% against input voltage
Input Voltage	60 V Max
Insulation Voltage	500V-1 min Residue < 5 μA
Vibration	IEC 68-2-6:1982 10g
Shock	IEC 68-2-29:1968 40g



# PY2

## LINEAR MOTION POSITION SENSORS

Mini Series □ 18 Section, STANDARD 10-50mm

### ORDER CODE

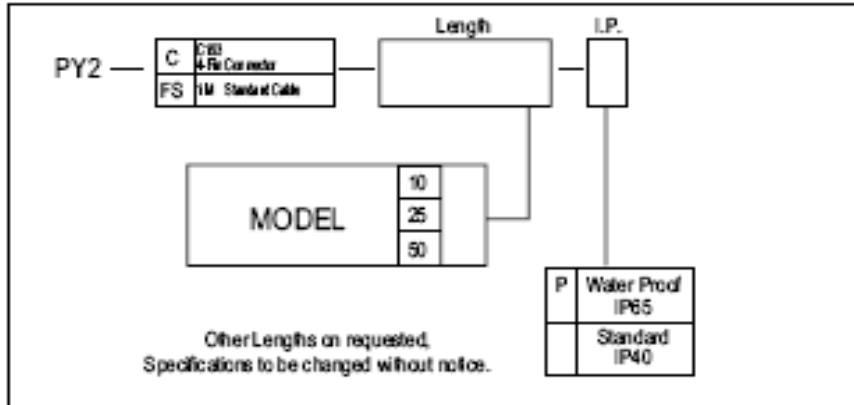

### ELECTRICAL CONNECTIONS

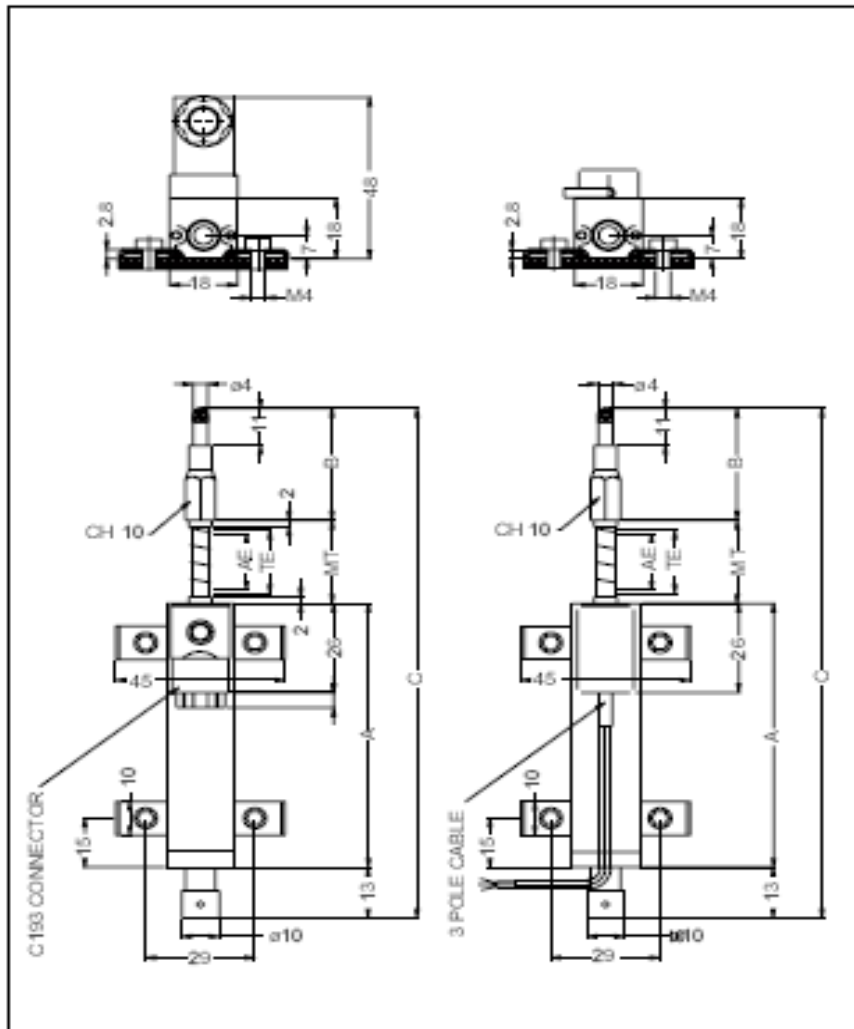
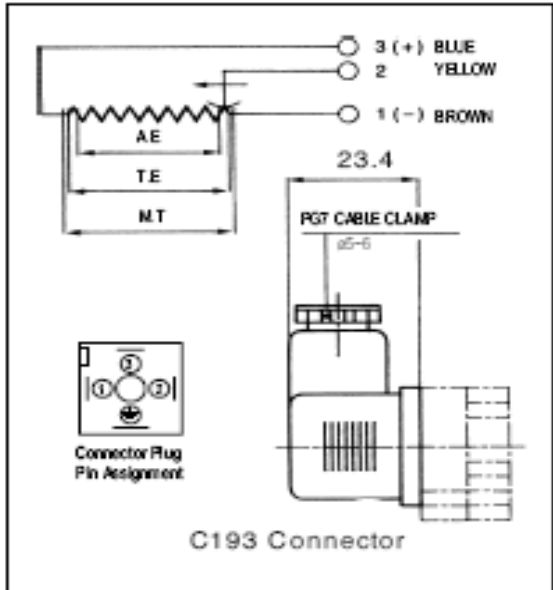

PY2 series		10	25	50
Total Electrical Travel (TE)	mm	11	26	51
Active Electrical Travel (AE)	mm	10	25	50
Resistance $\pm 20\%$	k $\Omega$	1	1	5
Independent Linearity	$\pm\%$	0.3	0.2	0.1
Mechanical Travel (MT)	mm	15	30	55
Resolution		infinite		
Recommended Cursor Current	$\mu\text{A}$	< 1		
Temperature Range	$^{\circ}\text{C}$	-30 to +100		
Dimensions (A)	mm	48	68	88
Dimensions (B)	mm	32	32	40
Dimensions (C)	mm	108	138	166

\* Dimensions for reference only



# PY3

## LINEAR MOTION POSITION SENSORS

Mini Series □ 18 Section, STANDARD 10-50mm

### Roller Head Pre-loaded Spring Type

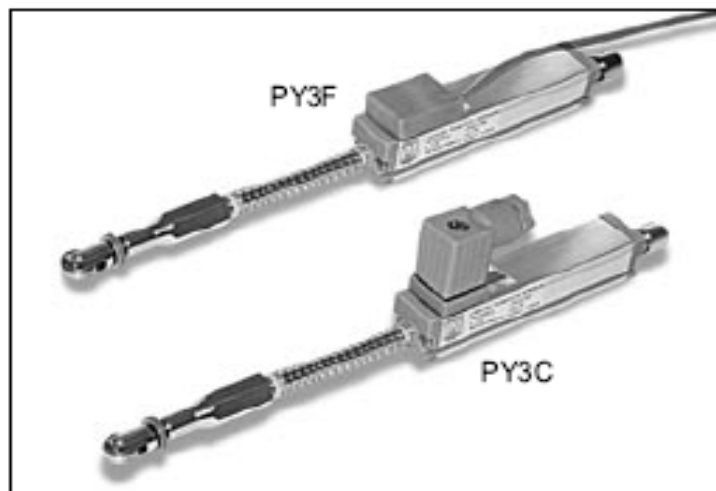

This mini position transducer is designed for direct absolute measurement and available in stroke length up to 50mm. The mini design is suitable for mounting in instruments or machines with limited space and specially design for moving stock application.

An improved technique for making connection to resistance track (Double Trimming Technique) ensures the higher degrees of reliability and linearity, while multi-fingers wipers stabilize output signals, even in the most adverse working conditions.

The fixing feet are adjustable to the desired position.

The bearing roller is suitable for measurement of moving pile stock thickness along moving direction.

#### Unique Features

- Harden steel bearing roller head for measurement of moving pile stock thickness
- Mini design for limited space
- Anodised Aluminium Housing
- Double slide and bearing
- Very Long Life
  - >100 x 10<sup>6</sup> Cycles
  - >25 x 10<sup>6</sup> m
- Stroke : 10-450mm
- Outstanding Linearity up to : ± 0.1%
- High Resolution : Infinite
- Excellent Repeatability : ± 0.01mm
- Max operating speed : 5m/s max.
- PY3C - 4 pin C193 connector
- PY3FS - standard 1m cable
- Sealing IP 40 standard (IP 65 optional)
- Fuse Protected Optional

Technical Specifications	
Sealing - PY3C/PY3FS	IP40
Sealing - optional	IP65
Current Resistance	≤ 10mA
Wiper	≤ 1mA
Operating Force	≤ 1.2N (IP40) ≤ 5N (IP65)
Power Consumption	3W-10W
Output Smoothness	<± 0.1% against input voltage
Input Voltage	60 V Max
Insulation Voltage	500V-1 min Residue < 5 μ A
Vibration	IEC 68-2-6:1982 10g
Shock	IEC 68-2-29:1968 40g





# PZ12 Series

## LINEAR MOTION POSITION SENSORS

Ø12.9 Section, STANDARD 10-150mm

### Pulling Rod Type

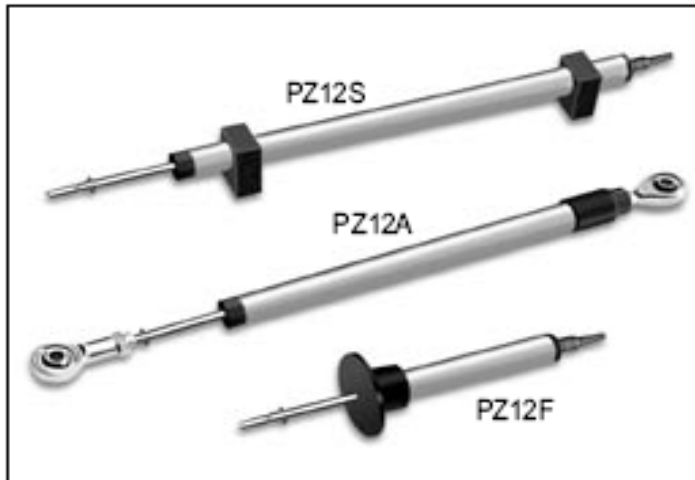

This mini position transducer is designed for direct absolute measurement and available in stroke length up to 150mm. The mini design is suitable for mounting in instruments or machines with limited space.

An improved technique for making connection to resistance track (Double Trimming Technique) ensures the higher degrees of reliability and linearity, while multi-fingers wipers stabilize output signals, even in the most adverse working conditions.

There are three ways of mountings to suit different applications.

PZ12S can be mounted by two adjustable brackets.

PZ12A can be mounted by self-aligning ball joints

PZ12F can be flange mounted

### Unique Features

- Mini design for limited space
- Anodised Aluminium Housing
- Three mounting methods
- Very Long Life
  - >100 x 10<sup>6</sup> Cycles
  - >25 x 10<sup>6</sup> m
- Stroke : 10-150mm
- Outstanding Linearity up to : ± 0.05%
- High Resolution : Infinite
- Excellent Repeatability : ± 0.01mm
- Max operating speed : 5m/s max.
- PZ12S - two adjustable brackets
- PZ12A - two self-aligning ball joints
- PZ12F - flange mounted
- Sealing IP 60 standard (IP 65 optional)
- Fuse Protected optional
- Operating temperature : -30 ~100°C
- Storage Temperature : -50 ~120°C

Technical Specifications	
Sealing - PZ12S/PZ12A/PZ12F	IP60
Sealing - optional	IP65
Current	Resistance ≤ 10mA
	Wiper ≤ 1mA
Operating Force	≤ 0.5N (IP60)
	≤ 5N (IP65)
Power Consumption	3W-10W
Output Smoothness	< ± 0.1% against input voltage
Input Voltage	60 V Max
Insulation Voltage	500V-1 min Residue < 5 μA
Vibration	IEC 68-2-6:1982 10g
Shock	IEC 68-2-29:1968 40g



# PZ12 Series

## LINEAR MOTION POSITION SENSORS

Ø12.9 Section, STANDARD 10-150mm

### ELECTRICAL CONNECTIONS

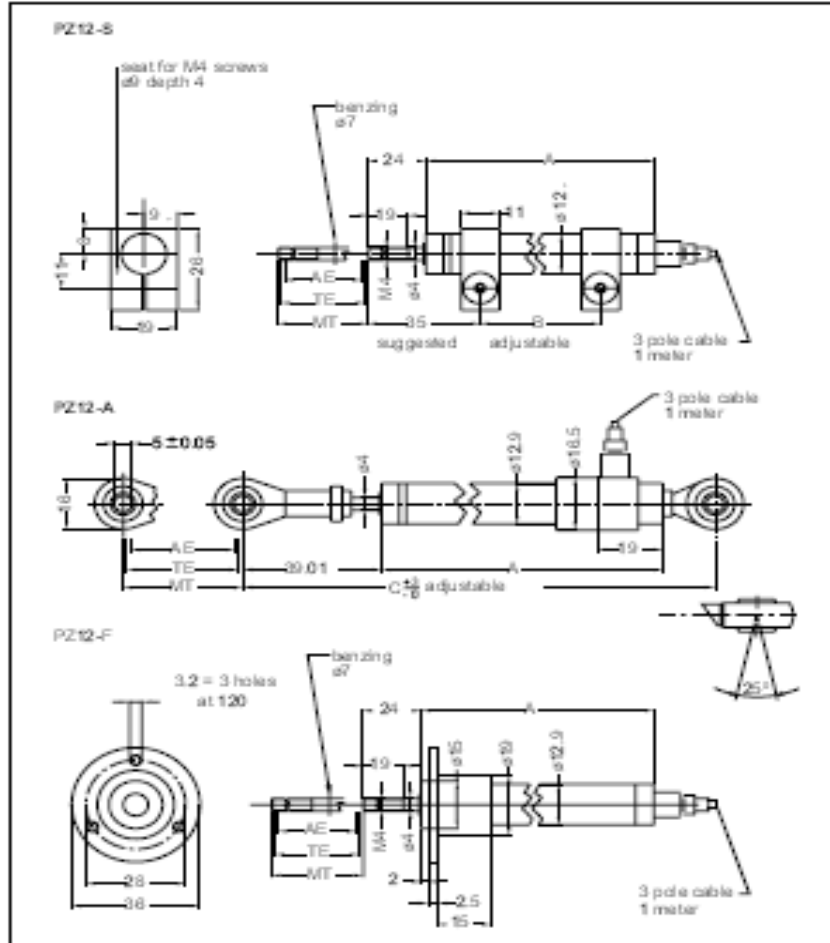

### ORDER CODE

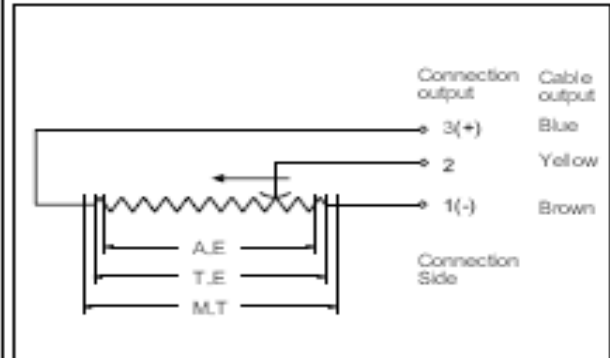
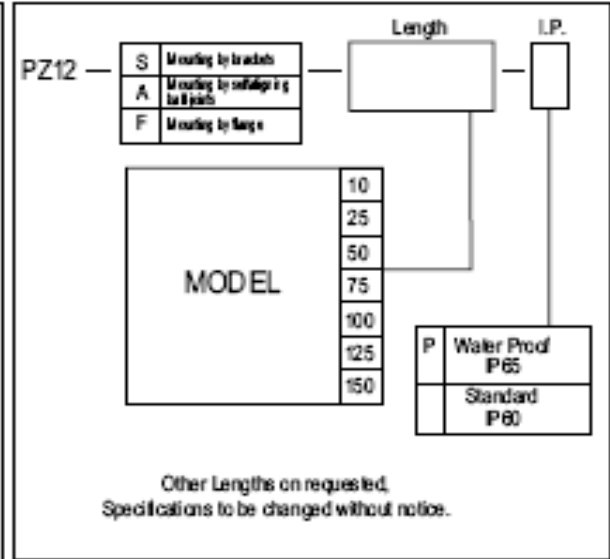

PZ12 series		10	25	50	75	100	125	150
Total Electrical Travel (T.E)	mm	11	26	51	76	101	126	151
Active Electrical Travel (A.E)	mm	10	25	50	75	100	125	150
Resistance ±20%	kΩ	1	1	2	3	4	5	5
Independent Linearity	%	0.3	0.2	0.1	0.1	0.1	0.05	0.05
Mechanical Travel (M.T)	mm	15	30	55	80	105	130	155
Resolution		infinite						
Recommended Cursor Current	µA	< 1						
Temperature Range	°C	-30 to +100						
Dimensions (A) PZ12-S	mm	58.5	74.5	99.5	124.5	149.5	174.5	199.5
Dimensions (A) PZ12-A	mm	67	102	127	152	177	202	227
Dimensions (A) PZ12-F	mm	58.5	74.5	99.5	124.5	149.5	174.5	199.5
Dimensions (B)	mm	27	42	67	92	117	142	167
Dimensions (C)	mm	136	156	176	205	235	265	278
Net Weight PZ12-S	g	30	45	65	85	105	125	145
Net Weight PZ12-A	g	55	70	90	110	130	150	170
Net Weight PZ12-F	g	45	60	80	100	120	140	160

\*Dimensions for reference only



# PZ34 Series

## LINEAR MOTION POSITION SENSORS

Ø19 Section, STANDARD 10-250mm

### Pulling Rod Type



#### Unique Features

- Mini design for limited space
- Anodised Aluminium Housing
- Very Long Life
  - >100 x 10<sup>6</sup> Cycles
  - >25 x 10<sup>6</sup> m
- Stroke : 10-250mm
- Outstanding Linearity : ±0.05%
- High Resolution : Infinite
- Excellent Repeatability up to : ± 0.01mm
- Max operating speed : 5m/s max.
- Three mounting methods
- PZ34S - two adjustable brackets
- PZ34A - two self-aligning ball joints
- PZ34F - flange mounted
- Sealing IP 60 standard (IP 65 optional)
- Fuse Protected optional
- Operating temperature : -30 ~100°C
- Storage Temperature : -50 ~120°C

This mini position transducer is designed for direct absolute measurement and available in stroke length up to 250mm. The mini design is suitable for mounting in instruments or machines with limited space.

An improved technique for making connection to resistance track (Double Trimming Technique) ensures the higher degrees of reliability and linearity, while multi-fingers wipers stabilize output signals, even in the most adverse working conditions.

There are three ways of mountings to suit different applications

PZ34S can be mounted by two adjustable brackets.

PZ34A can be mounted by self-aligning ball joints

PZ34F can be flange mounted

Technical Specifications		
Sealing - PZ34S/PZ34A/PZ34F		IP60
Sealing - optional		IP65
Current	Resistance	≤ 10mA
	Wiper	≤ 1mA
Operating Force		≤ 0.5N (IP60)
		≤ 5N (IP65)
Power Consumption		3W-10W
Output Smoothness		<± 0.1% against input voltage
Input Voltage		60V Max
Insulation Voltage		500V-1 min Residue < 5 μA
Vibration	IEC 68-2-6:1982	10g
Shock	IEC 68-2-29:1968	40g



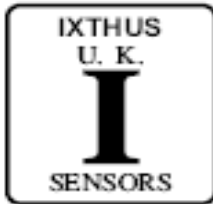

# IC Series

## Conductive Plastic Element

### For Mounting Inside Hydraulic or Pneumatic Cylinder

#### STANDARD 25-900mm



This IC Conductive Plastic Element is suitable to be installed in high pressure chamber of small cylinders or large cylinders.

The Standard range of this element is 25~900mm. Longer range and special sizes are available on request. This element can be mechanically fixed by internal or external flange. It is suitable to be used in explosive environments with presence of groups IIA, IIB, IIC, gas and combustible powders if the element is correctly and perfectly sealed.

### Unique Features

- Easy mechanical mounting
- Anodised Aluminium stem material
- Very Long Life
  - >100 x 10<sup>6</sup> Cycles
  - >25 x 10<sup>6</sup> m
- Stroke : 25-900mm
- Outstanding Linearity up to : ± 0.05%
- High Resolution : Infinite
- Excellent Repeatability up to : ± 0.01mm
- Max operating speed : 5m/s max.
- ICC: 6 pole connector
- ICF: 3 free wires (200mm length)
- Operating temperature : -30 ~100°C
- Storage Temperature : -50 ~120°C
- Stainless steel AISI 303 Flange material
- Internal or external flange version

Technical Specifications	
Independent linearity	± 0.1%, ±0.05%
Current Resistance	≤ 10mA
Wiper	≤ 1mA
Recommended cursor current	< 0.1 μA
Electrical isolation	>100MΩ at 500V~, 1bar, 2s
Dielectric strength	<100 μA at 500V~, 50Hz, 2s, 1bar
Working temperature	-30~100°C
Storage temperature	-50~120°C
Operating Force	≤ 1N

### ORDER CODE

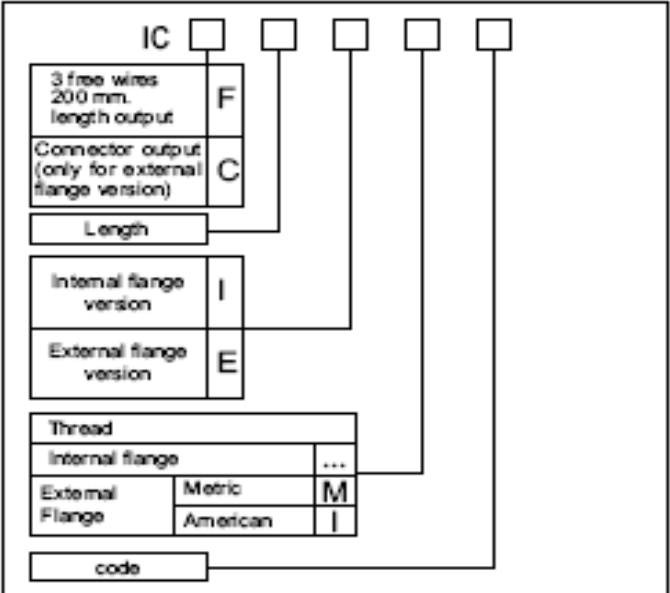



# IC Series

## Conductive Plastic Element

### For Mounting Inside Hydraulic or Pneumatic Cylinder

#### STANDARD 25-900mm

### MECHANICAL DIMENSIONS

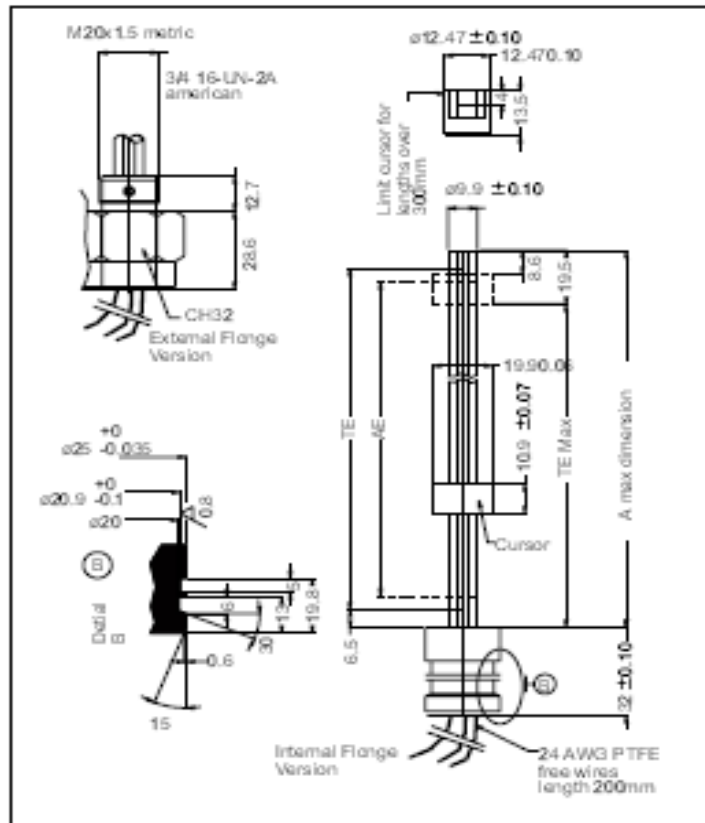

### ELECTRICAL CONNECTIONS

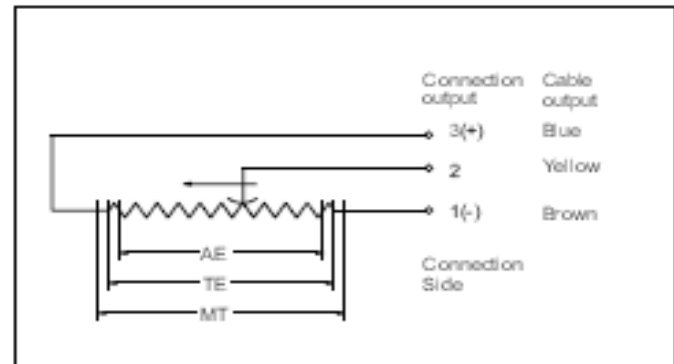

### EXT. FLANGE VERSION / CONNECTIONS

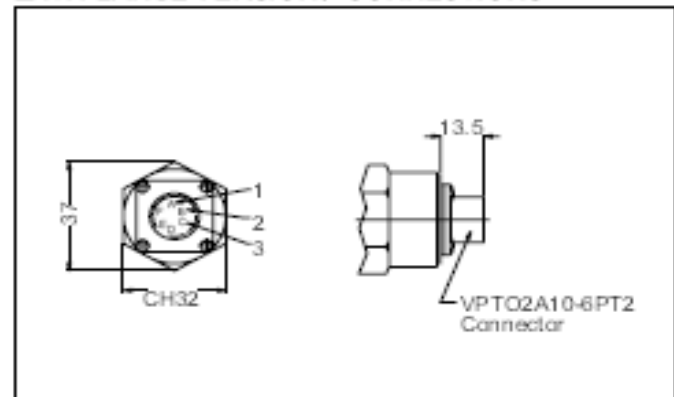

IC series		25	50	100	150	200	250	300	350	400	450	500	550	600	650	700	750	800	900	
Total Electrical Travel (T.E)	mm	35	60	110	160	210	260	310	360	410	460	510	560	610	660	710	760	810	910	
Active Electrical Travel (A.E)	mm	29	54	104	154	204	254	304	354	404	454	504	554	604	654	704	754	804	904	
Resistance ±20%	kΩ	5	5	10	10	10	10	10	10	10	10	10	10	10	10	10	10	10	10	
Independent Linearity	%	0.1	0.1	0.1	0.1	0.1	0.1	0.1	0.1	0.1	0.1	0.1	0.1	0.1	0.1	0.1	0.1	0.1	0.1	
Mechanical Travel (M.T)	mm	29	54	104	154	204	254	304	354	404	454	504	554	604	654	704	754	804	904	
Resolution		infinite																		
Recommended Cursor Current	μA	< 1																		
Temperature Range	°C	-30 to +100																		
Dimensions (A)	mm	48.5	73.5	123.5	173.5	223.5	273.5	323.5	373.5	423.5	473.5	523.5	573.5	623.5	673.5	723.5	773.5	823.5	923.5	

\*Dimensions for reference only

# Motion and Displacement Transducer Conductive Plastic

## 1. INTRODUCTION

The conductive plastic potentiometers (voltage divider) were introduced in late Fifties and become wide application in automobiles, plastic injection machines, wood working machines and various branches of industries today. The sensors, relatively inexpensive, inert to temperature variation, low torque operation and high speed application are the unique features of conductive plastic technology.

The sensor comprises the below important elements.

- The track resistance
- A wiper
- Actuation unit
- Alignment bearing
- Housing

## 2. The elements

### 2.1 The resistance track

The resistance track is the most important element of the sensor. It has a conductive plastic paste laid on it and can be round or straight to make a rotational potentiometer or a linear transducer. The plastic paste is a co-polymer filler with very fine conductive carbon black. The track is then trimmed to the required linearity.

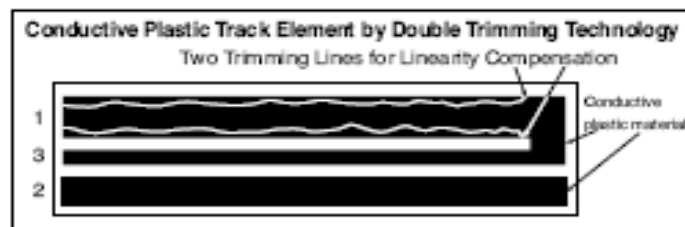

**Double Trimming Track Technology for creating extra high linearity.**

### 2.2 Wiper

The wiper is the critical part for current sensing. It makes of precious metals and with multi-fingers structure to provide long life, damped impulse and vibration, corrosive prevention, low torque, high speed operation (10m/s) and long life (>100 million cycles).

### 2.3 Actuation unit

It may consists either a draft shaft or actuating rod.

### 2.4 Alignment bearing

provides correction for installation misalignment.

### 2.5 Housing

It is normally made of aluminium with surface anodized to house and protect other elements.

## 3. Function and principle

The function of a motion transducer is to convert a mechanical displacement into an electrical signal and the signal can be made directly proportional to the mechanical movement.

The wiper assembly connected to the mechanical actuator is now moved on the plastic track to make a voltage divider. The track of the potentiometer (1,3) is connected to a stabilised input DC voltage which allow a small current flow. The signal voltage, when measured between the wiper and the trimmed track is the principal of voltage divider and is directly proportional to the position of the wiper on the track.

The use of the potentiometer as a voltage divider can minimizes the necessity for accuracy of the total resistance of the track since the temperature fluctuation only affects the changes in resistance, does not affect the measured result.

## 4. Conductive plastic poteutiomenters application

Such sensors are commonly used in various fields,

- automobile
- Medical equipment
- Robotics
- Wood working machinery
- Moulding machinery

With increasing focus on wheel alignment, electrical cars, physiotherapy and auto pilot trafficking systems

## 5. How to choose a motion transducer

Important parameters includes

- the accuracy, linearity required
- the expectancy life span
- the repeatability / resolution
- the torque (low) requirement
- the environment, vibration, dust, temperature, humidity, etc.
- the speed requirement, and of course, the price / life expectation.

## 6. Linearity

### 6.1 Total applied voltage $V_o$

The total voltage applied between the designated input terminals.

$V_o$  = Total applied voltage (peak to peak for AC voltage)

# Motion and Displacement Transducer Conductive Plastic

## 6.2 Output voltage; signal voltage $v$

The voltage between the wiper and the reference points, usually, is the zero terminal.

## 6.3 Output voltage $\frac{v}{V_0}$

The ratio of the signal to the applied voltage

## 6.4 Conformity

The fidelity of the relationship between the actual function characteristic and the theoretical function characteristic

$$\frac{v}{V_0} = f(\theta) + C$$

## 6.5 Linearity definition

A specific type of conformity where the theoretical function characteristic is a straight line

$$\frac{v}{V_0} = f(\theta) + C = A(\theta) + B + C$$

Where A is a given slope; B is given intercept at  $\theta = 0$

### 6.5.1 Independent Linearity

The maximum deviation of the actual function characteristic from a reference straight line (Best suit line) with its slope and position calculated to minimize the maximum deviations, It is expressed as a percentage of the total applied voltage and is measured over the specified theoretical electrical travel.

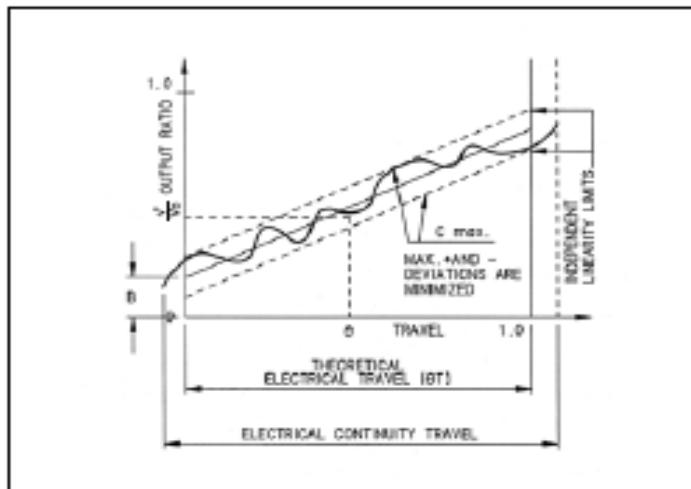

### 6.5.2 Absolute Linearity

This linearity is harder to achieve because it is the maximum deviation of the actual function characteristic from a fully defined straight reference line. It is expressed as a percentage of the total applied voltage and measured voltage over the theoretical electrical travel. An index point on the actual output is required.

The straight reference line may be fully defined by specifying the low and high theoretical end output ratios separated by the theoretical electrical travel. Unless otherwise specified, these end output ratio are 0,0 and 1,0 respectively, where A is a given slope; B is a given intercept at  $\theta=0$  unless otherwise specified  $A=1$ ;  $B=0$

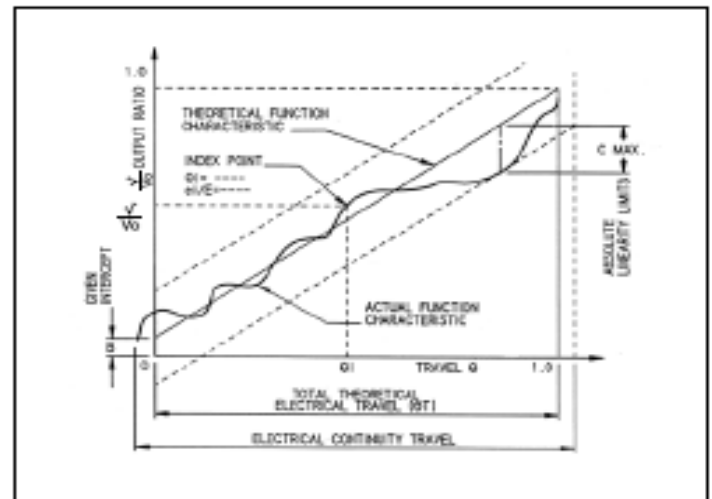

## 7. Life Expectancy

The number of shaft revolutions or travels obtainable under specific operating conditions and within specified allowable degradations of specific characteristics

## 8. Resolution

A measure of the sensitivity to which the output ratio of the potentiometer may be set.

## 9. Repeatability

It is the maximum difference found in the output ratio for a same mechanical position all along the theoretical electrical stroke after several travels. It may be expressed as a percentage of the total applied voltage or absolute travel distance.

## 10. Travels

### 10.1 Theoretical electrical travel: T.E.

The specified shaft travel over which the theoretical function characteristic and its associated conformity limits are respected.

### 10.2 Actual electrical travel: A.E.

The total travel of the shaft between the two points which the first and the last measurable change in output ratio occur.

# Motion and Displacement Transducer Conductive Plastic

## 10.3 Mechanical travel: M.T.

The total travel of the shaft between integral stops. In potentiometers without stops, the mechanical travel is continuous (rotational only)

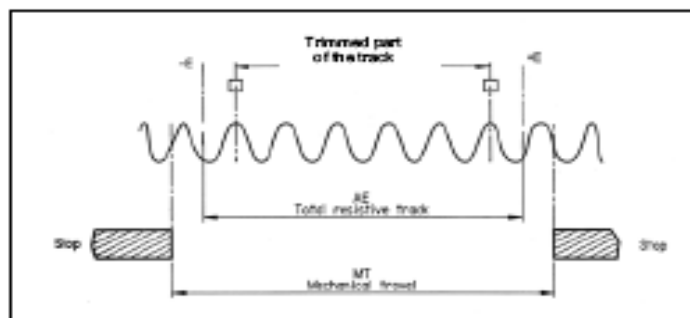

## 11. Gradient

The rate of change of output ratio relative to shaft travel.

$$G = \frac{\frac{dv}{V}}{\frac{d\theta}{\theta}} \quad (\text{mV/V}^\circ) \quad (\text{rotational})$$

$$G = \frac{\frac{dv}{V}}{dl} \quad (\text{mV/mm}) \quad (\text{linear})$$

## 12. Index Point

A point of reference fixing the relationship between a specified shaft position and the output ratio. It is used to establish a shaft position reference.

## 13. Output Smoothness

Output smoothness is a measurement of any spurious variation in the electrical output not present in the input. It is expressed as a percentage of the total applied voltage and measured for specified travel increments over the theoretical electrical travel. Output smoothness includes effects of contact resistance variations, resolution, and other micro-nonlinearities in the output

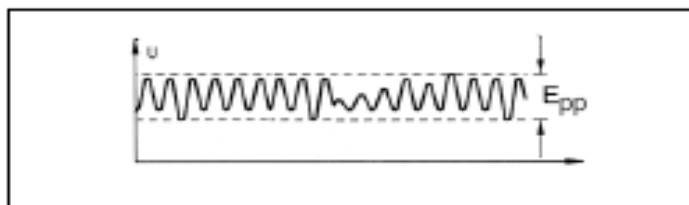

$E_{pp}$  : maximum variations peak to peak

$$RTS = \frac{E_{pp}}{V} 100 = \dots \%$$

## 14. End Voltage

The voltage between the wiper terminal and an end terminal when the shaft is positioned at the corresponding end of electrical continuity travel. End voltage is expressed as a percentage of the total applied voltage.

## 15. Voltage Tap

An electrical connection fixed to the resistance element which introduces no significant distortion in the output characteristic. A voltage tap usually has significant tap resistance and may not be capable of carrying rated element current.

A voltage tap involves a fourth turret which delivers a fixed voltage. This voltage only depends on the position of the tap on the track and of the total applied voltage. It is usually located in the middle of the T.E.

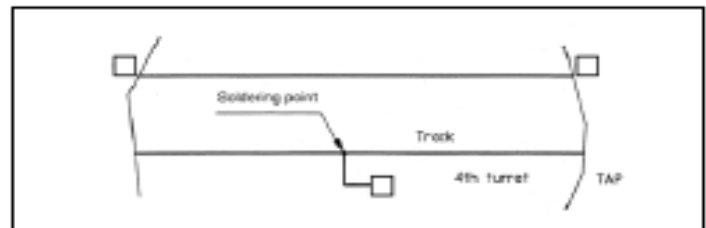

## 16. Starting Torque

The moment in the clockwise and counterclockwise directions required to initiate shaft rotation anywhere in the total mechanical travel.

## 17. Moment of Inertia

The mass moment of inertia of the rotating elements of the potentiometer about their rotational axis.

## 18. Contact resistance

Contact resistance is the resistance between the wiper terminal and the wiper's immediate point of contact on the potentiometer's resistive track. As will be subsequently explained, this contact resistance affects all the important quality features of a potentiometer.

Contact or transition resistance can be broken down into three components.

The first component, the internal component, describes the integral voltage drop between the current-carrying track and the contact surface.

This component is largely dependent on technology factors and amounts to several hundred Ohm. The second component, the external component, is far more difficult to master than the first.



# Motion and Displacement Transducer Conductive Plastic

This external transition resistance has much in common with the contact resistances occurring in switches and plug-and socket connectors. It is caused by the transition between the wiper and the potentiometer track not being ideal from an electrical viewpoint. Metal oxides, chlorides and sulphides (3), mixed with various organic substances, can result in the formation of thin nonconductive facings at the interface.

If not kept within bounds, this external transition resistance can, under unfavourable conditions, lead to complete failure to keep within a tolerance range. It is absolutely essential that the materials used in potentiometer manufacture be subjected to stringent quality control and be matched one with another.

The third component, the dynamic component, is related to dynamic drive forces acting on the wiper at high speeds of actuation. With the aid of damped wipers, actuation speeds of up to 10 m/sec can be achieved without any appreciable increase in the dynamic component of contact resistance.

## 19. Linearity errors due to electrical circuitry

From here onwards, we are only concerned with the linear characteristics (linearity). Relationships must be suitably adapted for applications with non-linear characteristics (conformity) but there are no essential difference.

As already mentioned, the required linearity values can only be utilized so long as the signal output by the sensor "potentiometer" carries no current.

The wiper current will distort the accuracy by 1% with current increase from 1 A to 10 A.

## 20. Linearity errors resulting from mechanical coupling

If there is axial misalignment (eccentricity) between the drive shaft and the shaft of a potentiometer used to sense angular motion, this will cause a linearity error that increases as the coupling radius decreases in relation to the degree of eccentricity. The following equation determines the maximum relative error

$$F_{\max} = E/\pi r_c$$

where  $E$ =Eccentricity and  $r_c$ =the coupling radius.

It is only possible to take full advantage of the linearity or conformity of potentiometers, as indeed of any rotary sensor system, if coupling alignment errors (offset and angular misalignment) are avoided or at least reduced to a minimum. This means that with highly accurate measurement systems, due allowance must be made for any coupling misalignment in accordance with the above equation.

## 21. Temperature and humidity coefficients

In many data sheets issued by potentiometer manufacturers, reference is frequently made to the temperature coefficient ( $T_k$ ) and humidity coefficient ( $F_k$ ) of the nominal resistance. Where potentiometers are used as voltage dividers, these values are irrelevant. For this application, it is the  $T_k$  and  $F_k$  applicable to the voltage divider behaviour which are of significance.

It often also happens that the humidity is not kept constant while making  $T_k$  measurements, with a result that a mixture of  $T_k$  and  $F_k$  is often given as a temperature coefficient.

Detailed measurement have show that the  $T_k$  and  $F_k$  of the nominal resistance in conductive-plastic potentiometers (without housing) are of an order magnitude somewhat less than 200 ppm/°C and 500 ppm/% RH respectively. The  $T_k$  and  $F_k$  of the voltage-dividing behaviour are some two orders of magnitude lower which means that here changes within a range of less than 5 ppm/°C and 5 ppm/%RH can be expected, ensuring constancy over a wide temperature and humidity range. However, this advantage can only be utilized given a suitably designed housing and if, for example, no trimming resistances are used in the potentiometer circuit.

## 22. Service life

The magnitude of the contact resistance and the wear to which the resistance track is subjected and the resulting change in electrical characteristics determines the number of operations to which a potentiometer can be subjected and thus its service life. Although of considerable importance for industrial applications, no standard has so far been issued that specifies a service-life definition or particular method of testing.

It is, of course, most difficult to specify a value for wear or for an increase in contact resistance for a given number of actuation cycles since such values are markedly influenced by such external factors as temperature and humidity, and by mechanical and chemical influences.

Such values need to be established for each particular application. This applies to a lesser extent for the method of testing and here the establishment of a standard method would facilitate comparing the service life of various potentiometers.



Distributed by  
Machine Automation  
Products LLC  
1074 Yellow Pine Street  
Coon Rapids, MN 55433

Phone 763 757 0198  
Fax 763 757 4724

Distributed By  
SILGE ELECTRONICA S.A  
AVE.MITRE 950  
B1604AKN-FLORIDA  
BUENOS AIRES ARGENTINA.  
Tel: 5411 4730 1001  
Fax: 5411 4760 4950  
email: gharf@silge.com.ar

IXTHUS INSTRUMENTATION LTD  
225 Watling Street  
Towcester Northants  
NN12 6DD. United Kingdom  
Tel: 44 (0) 1256 771166 Fax: 44 (0) 1256 771616  
<http://www.ixthus.co.uk>  
email: [info@ixthus.co.uk](mailto:info@ixthus.co.uk)

Subject to technical modifications in the interests of progress, we reserve the right to amend specification without notice.