

TORQ/GARD™ Overload Clutches



3 x M Holes
EQUALLY SPACED

C DETECTOR
TRAVEL @ OVERLOAD

Features

IMC's Torq/Gard overload clutches help protect the entire drive train of your machinery from damage due to excessive torque generated by overloads and jamming. Instant reaction when torque exceeds preset limits provides protection far superior to that of clutches employing friction surfaces. Torq/Gard features include:

- ◆ Modular Design: one unit for direct drive, chain drive or other power transmission options
- ◆ Universal Mounting: eliminates special bore requirements
- ◆ Single Position, Automatic Reset
- ◆ Reversible
- ◆ Torque Repeatability

Torq/Gard™ Features

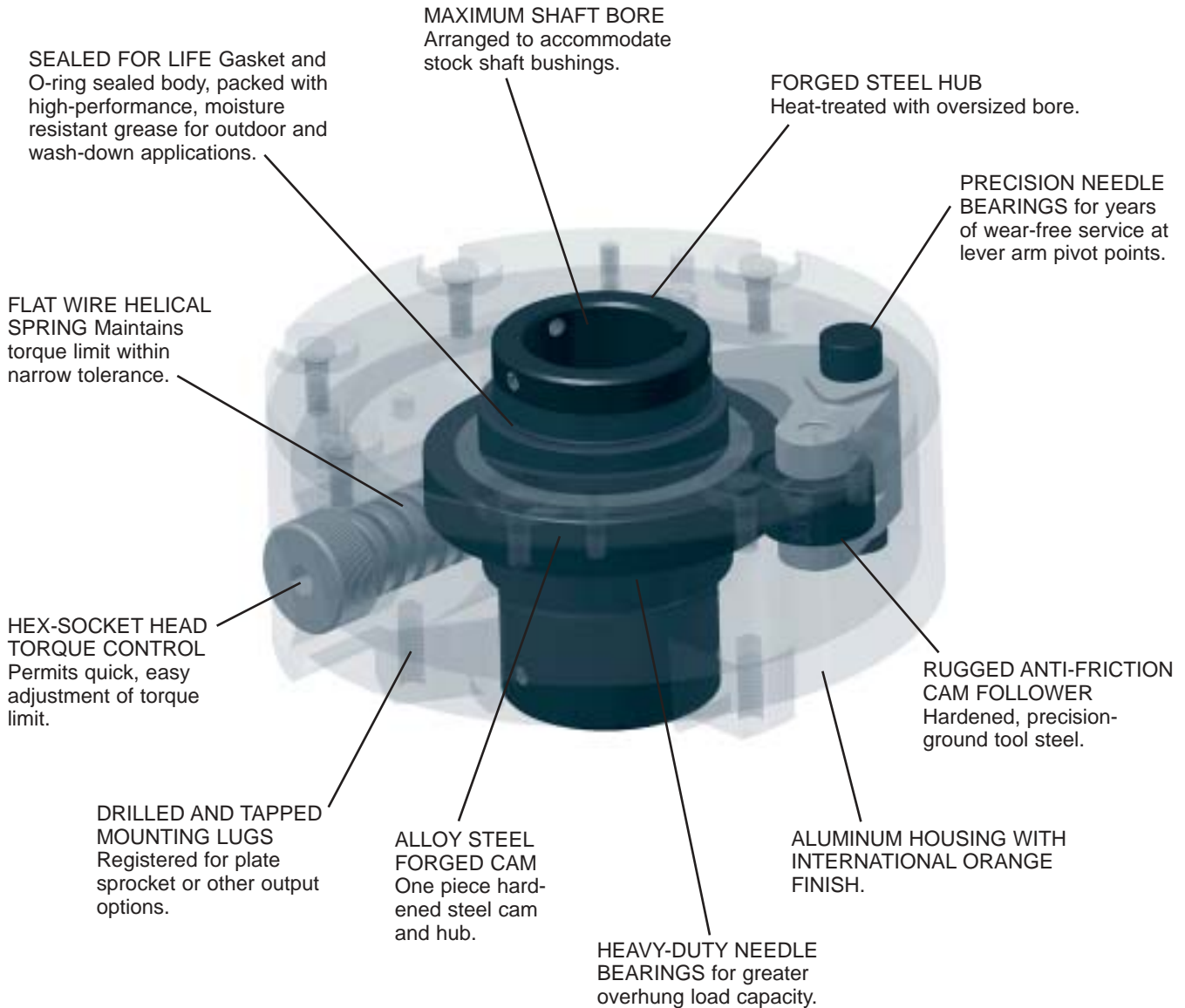

M

Torq/Gard™ Sizing and Selection

Torq/Gard overload clutches are available in seven sizes with capacities trip torques from 13 in-lbs to 8000 in-lbs.

Torq/Gard Clutches may be sized using the Speed-Horsepower Chart, the Speed-Torque Chart and these formulas:

$$\text{Torque (in-lb)} = \text{Horsepower (hp)} \times 63025 / \text{RPM}$$

$$\text{Horsepower (hp)} = \text{Torque (in-lbs)} \times \text{RPM} / 63025$$

$$\text{Tripping Torque (in-lbs)} = \text{Operating Torque} \times \text{Service Factor}$$

SPEED/HORSEPOWER CHART

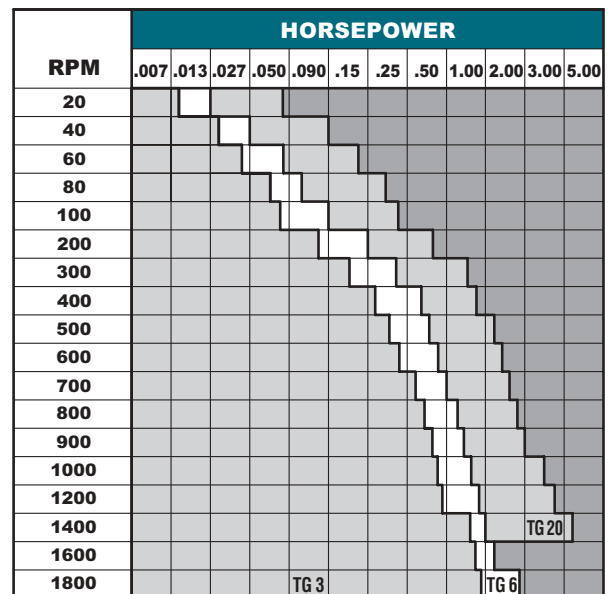
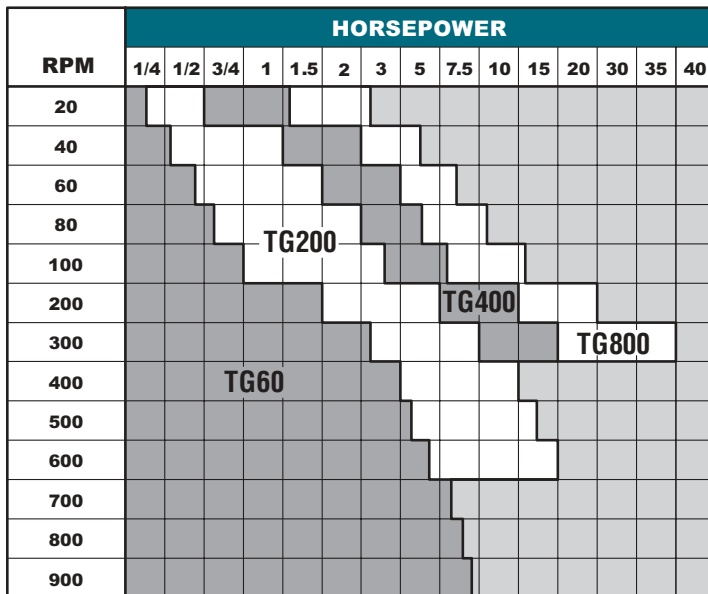

SPEED/TORQUE CHART

Model	Trip Torque (in-lbs)		HP Max	RPM Max	Weight (lbs)	Inertia (lb-in)	Maximum Bore Dia. (in)
	Min.	Max.					
TG3	13.3	32.7	1.5	1800	1.32	1.45	0.500
TG6	23	56.6	2.5	1800	1.32	1.45	0.500
TG20	56.6	204	4	1500	2.42	5.72	0.787
TG60	200	600	8.5	900	5.5	10	1 1/4
TG200	600	2000	21.5	680	12	46	1 15/16
TG400	2000	4000	22.2	350	38	455	2 7/16
TG800	4000	8000	44.4	350	38	455	2 7/16

Torq/Gard™ Dimensions

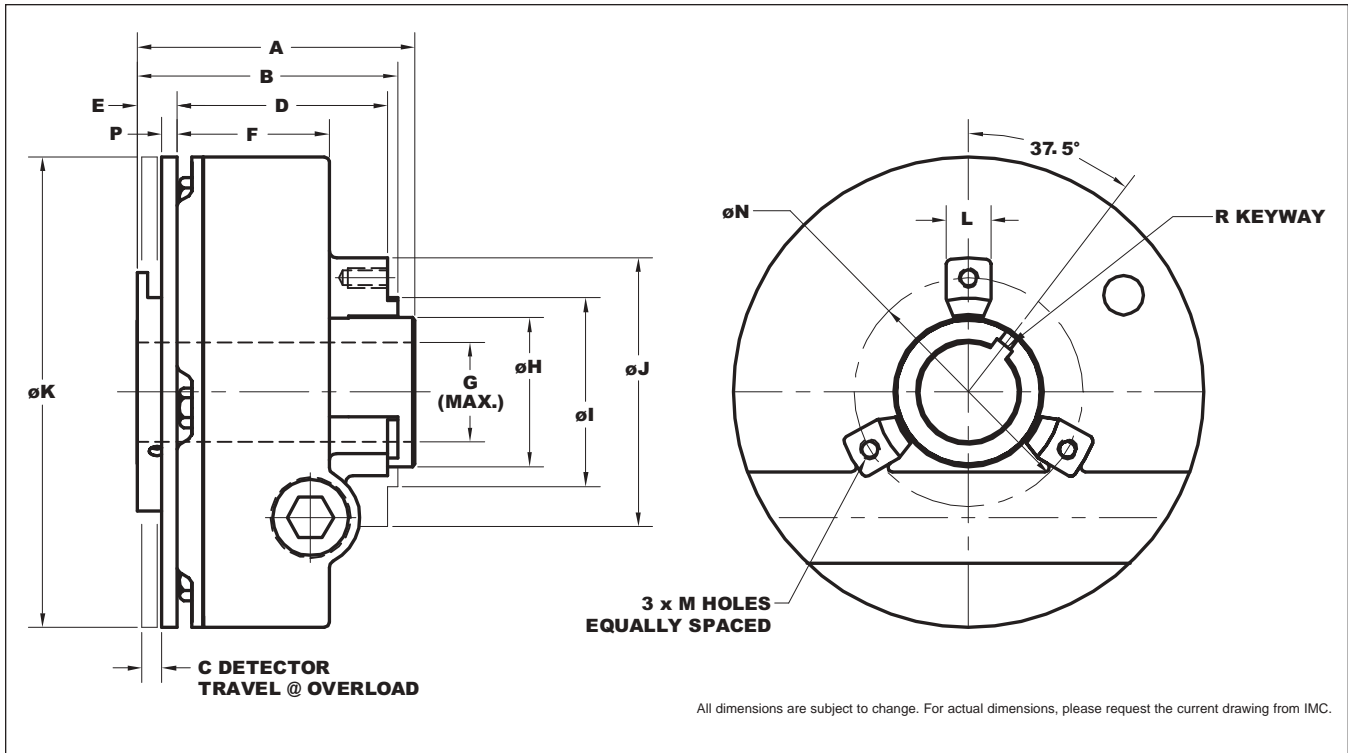

TORQ/GARD DIMENSIONS

Model	A	B	C	D	E	F	G	H	I	J	K	L	M	N	P	R
TG3	2.36	2.31	0.16	1.89	0.27	1.62	0.500	0.87	1.187	1.97	3.15	0.32	#8-32	1.575	0.12	0.125
TG6	2.36	2.31	0.16	1.89	0.27	1.62	0.500	0.87	1.187	1.97	3.15	0.32	#8-32	1.575	0.12	0.125
TG20	2.76	2.72	0.16	2.24	0.36	1.94	0.787	1.18	1.563	2.36	3.94	0.39	#10-24	1.965	0.12	0.188
TG60	3.50	3.28	0.25	2.67	0.49	1.97	1.250	1.88	2.375	3.38	5.25	0.56	.250-20	2.875	0.19	0.250
TG200	4.31	4.04	0.25	3.36	0.56	2.80	1.938	2.75	3.250	5.00	7.00	0.75	.375-16	4.500	0.19	0.500
TG400	6.19	6.14	0.31	5.17	0.62	3.80	2.438	3.50	4.500	7.50	10.75	1.12	.500-13	6.500	0.19	0.625
TG800	6.19	6.14	0.31	5.17	0.62	3.80	2.438	3.50	4.500	7.50	10.75	1.12	.500-13	6.500	0.19	0.625

Torq/Gard™ Application Considerations

The Torq/Gard should be used on the low speed side of a speed reducer in several ways:

- ◆ **Direct Drive:** The Torq/Gard can be mounting on the speed reducer output (low speed) shaft and directly connected to the driven machine using a Browning Ever-Flex half coupling and the Universal Adapter Plate.
- ◆ **Chain Drive – Mounted on Speed Reducer Output:** Mounting the Torq/Gard on the output of the gear motor or speed reducer with a roller chain connection to the driven machine provides the most economical clutch assembly. The Torq/Gard is designed to protect the weakest link in the drive system.

- ◆ **Chain Drive – Mounted on Driven Machine:** Mounting the Torq/Gard on the driven machine and powered through a chain and sprocket drive tends to absorb peak starting torques.
- ◆ **The Torq/Gard should never be used on the high speed side of a reducer.** Clutch sensitivity becomes a function of the reducer's gear ratio. As an example, when used with a 100:1 reducer, a 100 in-lb torque variation on the output side of the reducer will reflect only a 1 in-lb change on the input side. Do not exceed the maximum RPM shown in the Torq/Gard selection tables.

M